



## STANDARDIZED DEFORMATIONS

Quick delivery  
and favourable prices



# INDEX

- [M02 FORMING - EXTRUDED HOLE](#)
- [M04 FORMING - ROUND COUNTERSINK](#)
- [M09 SHEARING AND FORMING - SPRING CLIP](#)
- [M12 SHEARING AND FORMING - RADIUS BACK LOUVER](#)
- [M13 SHEARING AND FORMING - SHEAR BUTTON](#)
- [M14 ENGRAVING - GROUND SYMBOL](#)
- [M15 SHEARING AND FORMING - CONTINUOUS RADIUS BACK LOUVER](#)
- [M20 FORMING - CONTINUOUS OBOUNDED EMBOSS](#)



The most common forming are embosses, countersinks, engraving, logos, louvers and many more.

The great diffusion of these forming allows to handle a [wide offer of standardized products](#), reducing drastically delivery times and offering extremely favourable prices.

This type of forming is continuously growing and on the following pages you can see our current offer.

For detailed information and to know all the news, please contact our sales department.







Title	M02 04-1.0 Extruded hole for M4 thread	Station :	B Thick Turret	Date :	28/11/2012	Telephone :	0039 0445 671015
		Thickness :	0.80 ÷ 1.00	Rev :	0	Fax :	0039 0445 671035
Code :	FB09237421.305	Forming :	Up	Rev. Date :		E-Mail :	sales@matrixtools.eu

<http://www.matrixtools.eu/catalogues/deformations>

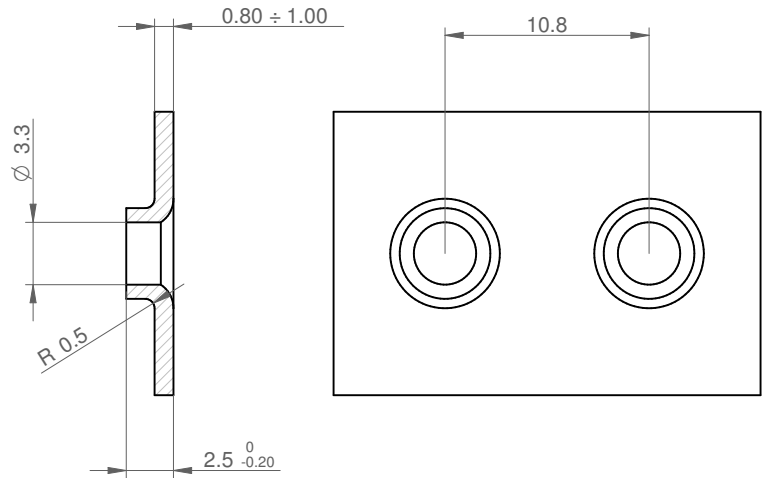

## SET OF INSERTS M02

- To be used on inserts Holder series WHITE and GREEN.
- This forming requires pre-pierce  $\varnothing 2,0 \pm 10\%$ .
- Multiple close formings might bend the sheet metal.
- Set of inserts composed of all elements showed on the side.

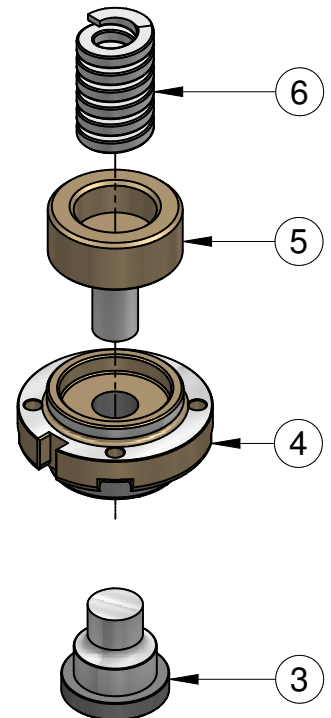

SET OF INSERTS M02			
POS.	DESCRIPTION	CODE	Q.ty
3	Lower Insert	FB09667121	1
4	Upper Insert	FB09247221.305	1
5	Ejector	FB09550021.305	1
6	Spring	A0903325.222	1

## UPPER INSERTS HOLDER

- Not included on the supply and not included on the price of the set of inserts.
- In case of order please specify one of the options indicated on the below table.

UPPER INSERTS HOLDER			
POS.	DESCRIPTION	CODE	✓
0	Not required	-	
1a	Adjustable round and shaped	FB08BA00	
1b	Adjustable round	FB09BA00	
1c	Fixed round and shaped	FB24BA00	
1d	Fixed round	FAZFBA00	

LOWER INSERTS HOLDER			
POS.	DESCRIPTION	CODE	✓
0	Not required	-	
2	Inserts Holder up to $\varnothing 10$	FAJ4BB00	





Title	M02 04-1.2 Extruded hole for M4 thread	Station :	B Thick Turret	Date :	06/11/2012	Telephone :	0039 0445 671015
		Thickness :	1.10 ÷ 1.30	Rev :	0	Fax :	0039 0445 671035
Code :	FB9237421.979	Forming :	Up	Rev. Date :		E-Mail :	sales@matrixtools.eu

<http://www.matrixtools.eu/catalogues/deformations>

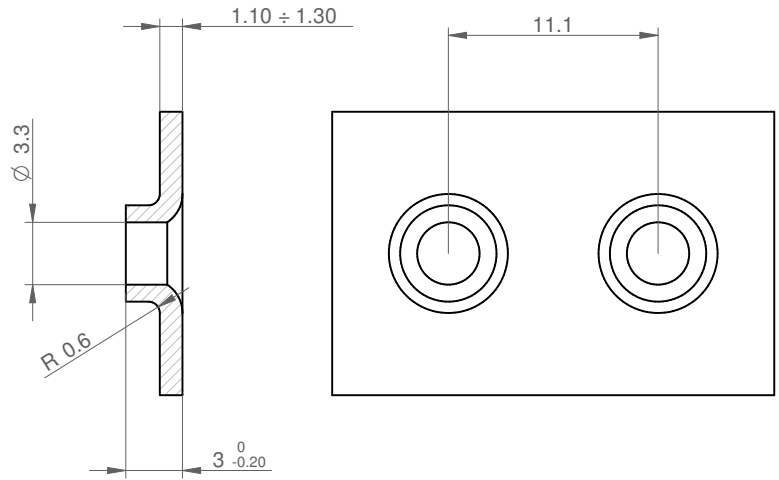

## SET OF INSERTS M02

- To be used on inserts Holder series WHITE and GREEN.
- This forming requires pre-pierce  $\varnothing 2,0 \pm 10\%$ .
- Multiple close formings might bend the sheet metal.
- Set of inserts composed of all elements showed on the side.

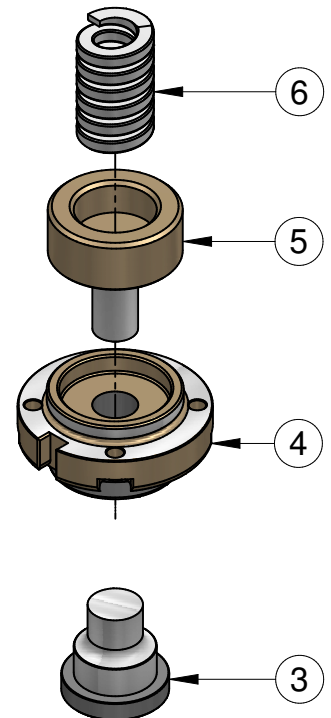

SET OF INSERTS M02			
POS.	DESCRIPTION	CODE	Q.ty
3	Lower Insert	FB09667121	1
4	Upper Insert	FB09247221.979	1
5	Ejector	FB09550021.979	1
6	Spring	A0903325.222	1

## UPPER INSERTS HOLDER

- Not included on the supply and not included on the price of the set of inserts.
- In case of order please specify one of the options indicated on the below table.

UPPER INSERTS HOLDER			
POS.	DESCRIPTION	CODE	✓
0	Not required	-	
1a	Adjustable round and shaped	FB08BA00	
1b	Adjustable round	FB09BA00	
1c	Fixed round and shaped	FB24BA00	
1d	Fixed round	FAZFBFA00	

LOWER INSERTS HOLDER			
POS.	DESCRIPTION	CODE	✓
0	Not required	-	
2	Inserts Holder up to $\varnothing 10$	FAJ4BB00	





Title **M02 04-1.5**  
**Extruded hole for M4 thread**

Code : **FB9237421.A43**

Station : **B Thick Turret**

Thickness : **1.40 ÷ 1.60**

Forming : **Up**

Date : **06/11/2012**

Rev : **0**

Rev. Date :

Telephone : **0039 0445 671015**

Fax : **0039 0445 671035**

E-Mail : **sales@matrixtools.eu**

<http://www.matrixtools.eu/catalogues/deformations>

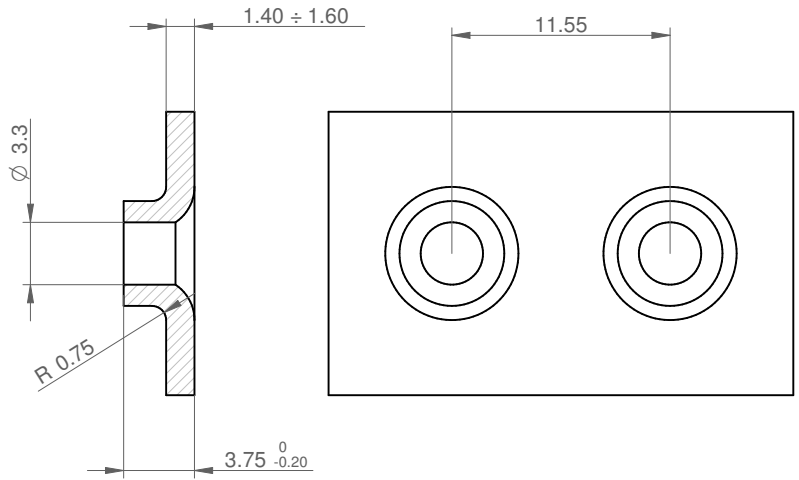

### SET OF INSERTS M02

- To be used on inserts Holder series WHITE and GREEN.
- This forming requires pre-pierce  $\varnothing 2,0 \pm 10\%$ .
- Multiple close formings might bend the sheet metal.
- Set of inserts composed of all elements showed on the side.

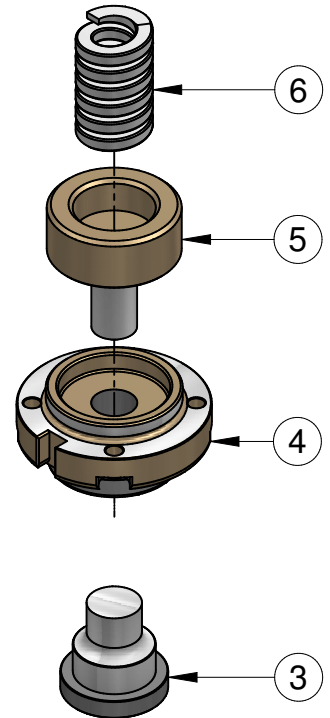

SET OF INSERTS M02			
POS.	DESCRIPTION	CODE	Q.ty
3	Lower Insert	FB09667121	1
4	Upper Insert	FB09247221.A43	1
5	Ejector	FB09550021.A43	1
6	Spring	A0903325.222	1

### UPPER INSERTS HOLDER

- Not included on the supply and not included on the price of the set of inserts.
- In case of order please specify one of the options indicated on the below table.

UPPER INSERTS HOLDER			
POS.	DESCRIPTION	CODE	✓
0	Not required	-	
1a	Adjustable round and shaped	FB08BA00	
1b	Adjustable round	FB09BA00	
1c	Fixed round and shaped	FB24BA00	
1d	Fixed round	FAZFBA00	

LOWER INSERTS HOLDER			
POS.	DESCRIPTION	CODE	✓
0	Not required	-	
2	Inserts Holder up to $\varnothing 10$	FAJ4BB00	





Title	M02 05-1.0 Extruded hole for M5 thread	Station :	B Thick Turret	Date :	03/12/2012	Telephone :	0039 0445 671015
		Thickness :	0.80 ÷ 1.00	Rev :	0	Fax :	0039 0445 671035
Code :	FB9237422.305	Forming :	Up	Rev. Date :		E-Mail :	sales@matrixtools.eu

<http://www.matrixtools.eu/catalogues/deformations>

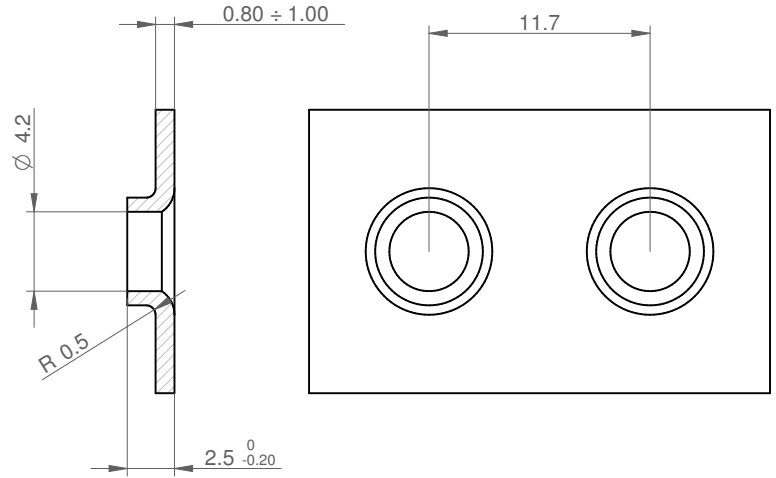

## SET OF INSERTS M02

- To be used on inserts Holder series WHITE and GREEN.
- This forming requires pre-pierce  $\varnothing 2,5 \pm 10\%$ .
- Multiple close formings might bend the sheet metal.
- Set of inserts composed of all elements showed on the side.

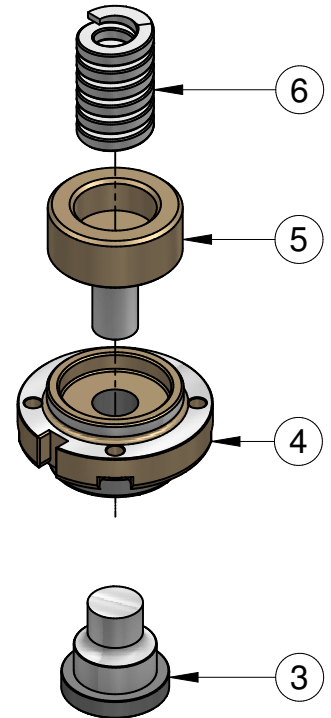

SET OF INSERTS M02			
POS.	DESCRIPTION	CODE	Q.ty
3	Lower Insert	FB09667122	1
4	Upper Insert	FB09247222.305	1
5	Ejector	FB09550022.305	1
6	Spring	A0903325.222	1

## UPPER INSERTS HOLDER

- Not included on the supply and not included on the price of the set of inserts.
- In case of order please specify one of the options indicated on the below table.

UPPER INSERTS HOLDER			
POS.	DESCRIPTION	CODE	✓
0	Not required	-	
1a	Adjustable round and shaped	FB08BA00	
1b	Adjustable round	FB09BA00	
1c	Fixed round and shaped	FB24BA00	
1d	Fixed round	FAZFBA00	

LOWER INSERTS HOLDER			
POS.	DESCRIPTION	CODE	✓
0	Not required	-	
2	Inserts Holder up to $\varnothing 10$	FAJ4BB00	





Title	M02 05-1.2 Extruded hole for M5 thread	Station :	B Thick Turret	Date :	03/12/2012	Telephone :	0039 0445 671015
		Thickness :	1.10 ÷ 1.30	Rev :	0	Fax :	0039 0445 671035
Code :	FB09237422.979	Forming :	Up	Rev. Date :		E-Mail :	sales@matrixtools.eu

<http://www.matrixtools.eu/catalogues/deformations>

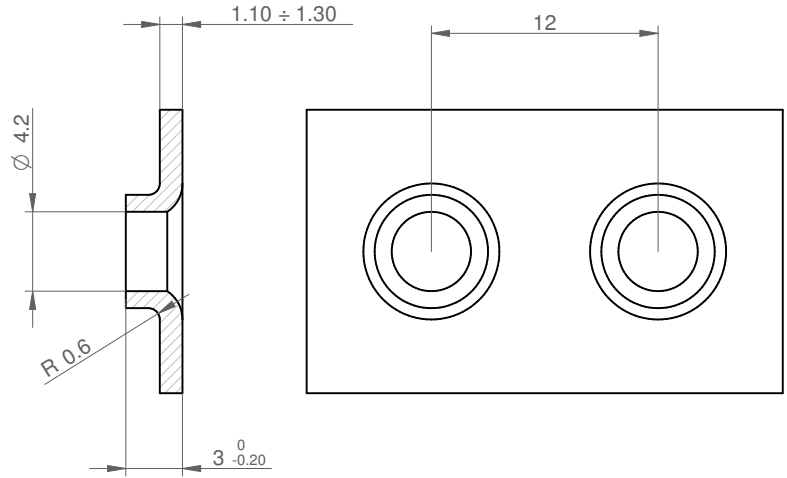

## SET OF INSERTS M02

- To be used on inserts Holder series WHITE and GREEN.
- This forming requires pre-pierce  $\varnothing 2,5 \pm 10\%$ .
- Multiple close formings might bend the sheet metal.
- Set of inserts composed of all elements showed on the side.

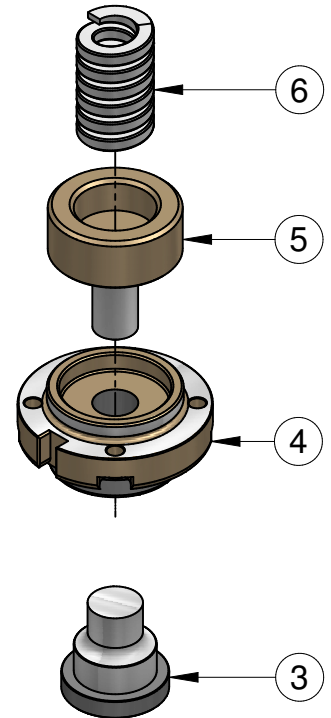

SET OF INSERTS M02			
POS.	DESCRIPTION	CODE	Q.ty
3	Lower Insert	FB09667122	1
4	Upper Insert	FB09247222.979	1
5	Ejector	FB09550022.979	1
6	Spring	A0903325.222	1

## UPPER INSERTS HOLDER

- Not included on the supply and not included on the price of the set of inserts.
- In case of order please specify one of the options indicated on the below table.

UPPER INSERTS HOLDER			
POS.	DESCRIPTION	CODE	✓
0	Not required	-	
1a	Adjustable round and shaped	FB08BA00	
1b	Adjustable round	FB09BA00	
1c	Fixed round and shaped	FB24BA00	
1d	Fixed round	FAZFBA00	

LOWER INSERTS HOLDER			
POS.	DESCRIPTION	CODE	✓
0	Not required	-	
2	Inserts Holder up to $\varnothing 10$	FAJ4BB00	





Title M02 05-1.5  
Extruded hole for M5 thread

Code : FB9237422.A43

Station : B Thick Turret

Thickness : 1.40 ÷ 1.60

Forming : Up

Date : 03/12/2012

Rev : 0

Rev. Date :

Telephone : 0039 0445 671015

Fax : 0039 0445 671035

E-Mail : sales@matrixtools.eu

<http://www.matrixtools.eu/catalogues/deformations>

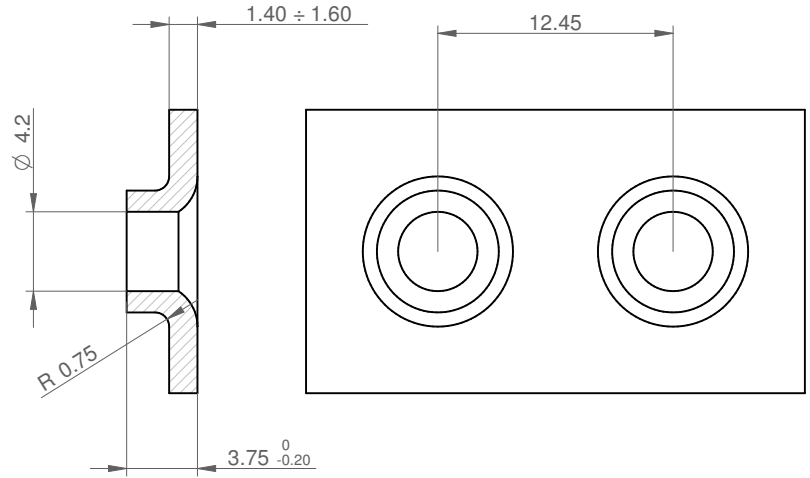

### SET OF INSERTS M02

- To be used on inserts Holder series WHITE and GREEN.
- This forming requires pre-pierce  $\varnothing 2,5 \pm 10\%$ .
- Multiple close formings might bend the sheet metal.
- Set of inserts composed of all elements showed on the side.

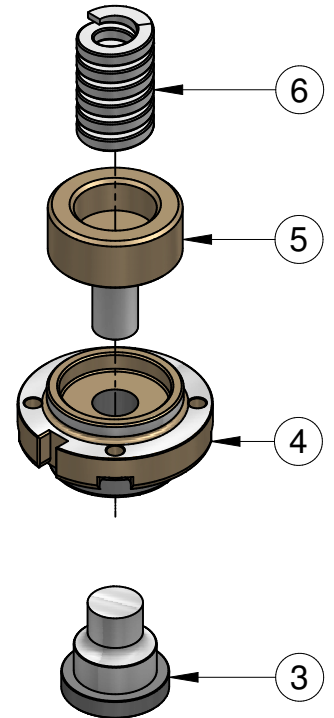

SET OF INSERTS M02			
POS.	DESCRIPTION	CODE	Q.ty
3	Lower Insert	FB09667122	1
4	Upper Insert	FB09247222.A43	1
5	Ejector	FB09550022.A43	1
6	Spring	A0903325.222	1

### UPPER INSERTS HOLDER

- Not included on the supply and not included on the price of the set of inserts.
- In case of order please specify one of the options indicated on the below table.

UPPER INSERTS HOLDER			
POS.	DESCRIPTION	CODE	✓
0	Not required	-	
1a	Adjustable round and shaped	FB08BA00	
1b	Adjustable round	FB09BA00	
1c	Fixed round and shaped	FB24BA00	
1d	Fixed round	FAZFBA00	

LOWER INSERTS HOLDER			
POS.	DESCRIPTION	CODE	✓
0	Not required	-	
2	Inserts Holder up to $\varnothing 10$	FAJ4BB00	







Title	M02 06-1.0 Extruded hole for M6 thread	Station :	B Thick Turret	Date :	03/12/2012	Telephone :	0039 0445 671015
		Thickness :	0.80 ÷ 1.00	Rev :	0	Fax :	0039 0445 671035
Code :	FB09237423.305	Forming :	Up	Rev. Date :		E-Mail :	sales@matrixtools.eu

<http://www.matrixtools.eu/catalogues/deformations>

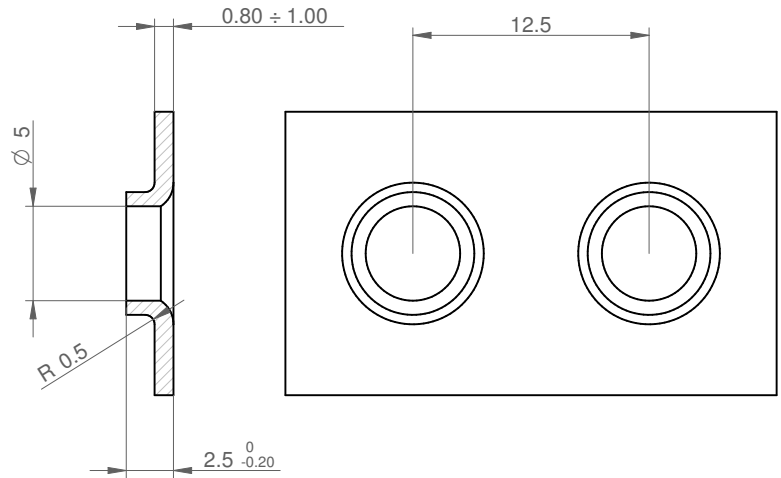

## SET OF INSERTS M02

- To be used on inserts Holder series WHITE and GREEN.
- This forming requires pre-pierce  $\varnothing 3,0 \pm 10\%$ .
- Multiple close formings might bend the sheet metal.
- Set of inserts composed of all elements showed on the side.

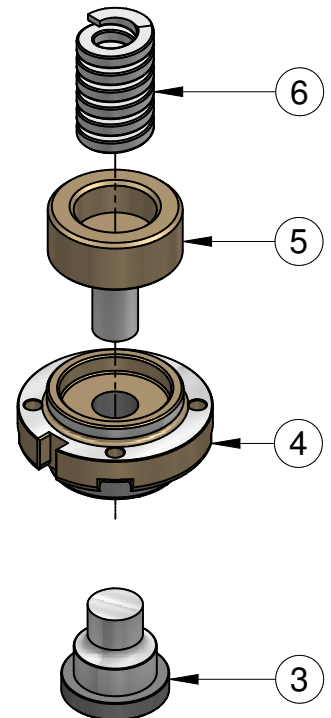

SET OF INSERTS M02			
POS.	DESCRIPTION	CODE	Q.ty
3	Lower Insert	FB09667123	1
4	Upper Insert	FB09247223.305	1
5	Ejector	FB09550023.305	1
6	Spring	A0903325.222	1

## UPPER INSERTS HOLDER

- Not included on the supply and not included on the price of the set of inserts.
- In case of order please specify one of the options indicated on the below table.

UPPER INSERTS HOLDER			
POS.	DESCRIPTION	CODE	✓
0	Not required	-	
1a	Adjustable round and shaped	FB08BA00	
1b	Adjustable round	FB09BA00	
1c	Fixed round and shaped	FB24BA00	
1d	Fixed round	FAZFBA00	

LOWER INSERTS HOLDER			
POS.	DESCRIPTION	CODE	✓
0	Not required	-	
2	Inserts Holder up to $\varnothing 10$	FAJ4BB00	





Title	M02 06-1.2 Extruded hole for M6 thread	Station :	B Thick Turret	Date :	03/12/2012	Telephone :	0039 0445 671015
		Thickness :	1.10 ÷ 1.30	Rev :	0	Fax :	0039 0445 671035
Code :	FB09237423.979	Forming :	Up	Rev. Date :		E-Mail :	sales@matrixtools.eu

<http://www.matrixtools.eu/catalogues/deformations>

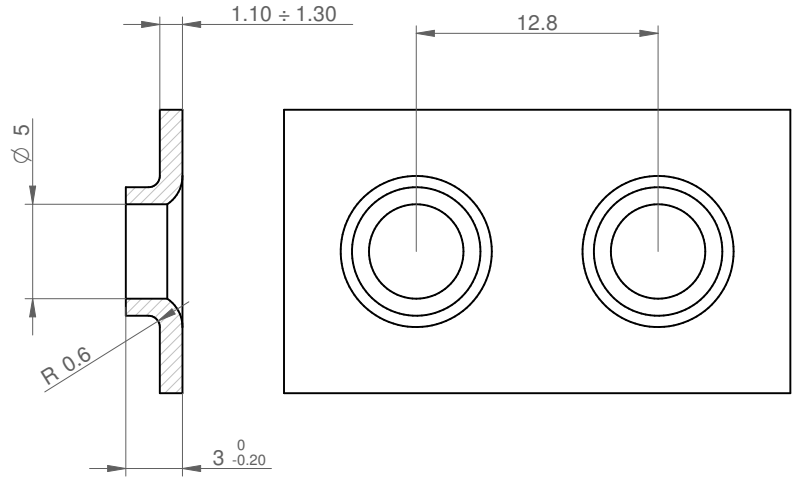

## SET OF INSERTS M02

- To be used on inserts Holder series WHITE and GREEN.
- This forming requires pre-pierce  $\varnothing 3,0 \pm 10\%$ .
- Multiple close formings might bend the sheet metal.
- Set of inserts composed of all elements showed on the side.

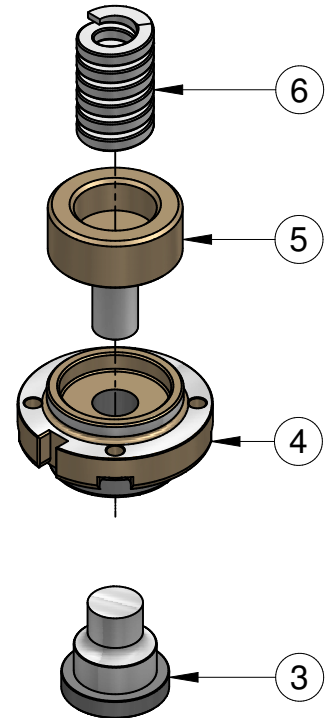

SET OF INSERTS M02			
POS.	DESCRIPTION	CODE	Q.ty
3	Lower Insert	FB09667123	1
4	Upper Insert	FB09247223.979	1
5	Ejector	FB09550023.979	1
6	Spring	A0903325.222	1

## UPPER INSERTS HOLDER

- Not included on the supply and not included on the price of the set of inserts.
- In case of order please specify one of the options indicated on the below table.

UPPER INSERTS HOLDER			
POS.	DESCRIPTION	CODE	✓
0	Not required	-	
1a	Adjustable round and shaped	FB08BA00	
1b	Adjustable round	FB09BA00	
1c	Fixed round and shaped	FB24BA00	
1d	Fixed round	FAZFBA00	

LOWER INSERTS HOLDER			
POS.	DESCRIPTION	CODE	✓
0	Not required	-	
2	Inserts Holder up to $\varnothing 10$	FAJ4BB00	





Title	M02 06-1.5 Extruded hole for M6 thread	Station :	B Thick Turret	Date :	03/12/2012	Telephone :	0039 0445 671015
		Thickness :	1.40 ÷ 1.60	Rev :	0	Fax :	0039 0445 671035
Code :	FB09237423.A43	Forming :	Up	Rev. Date :		E-Mail :	sales@matrixtools.eu

<http://www.matrixtools.eu/catalogues/deformations>

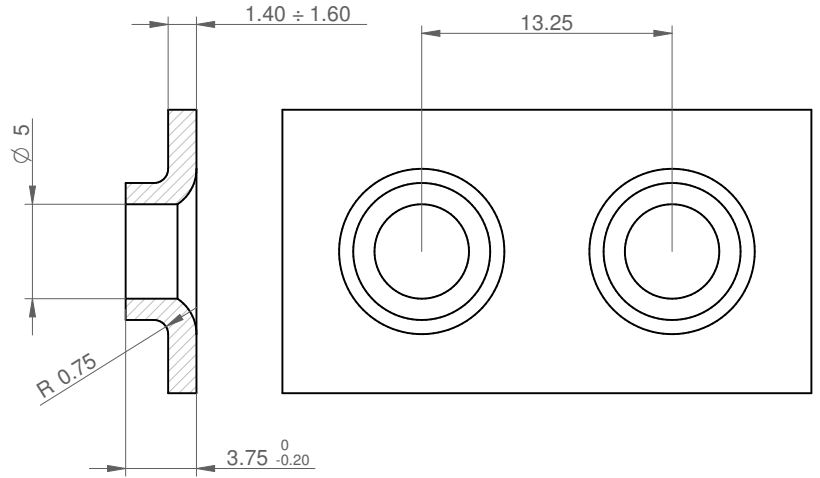

## SET OF INSERTS M02

- To be used on inserts Holder series WHITE and GREEN.
- This forming requires pre-pierce  $\varnothing 3,0 \pm 10\%$ .
- Multiple close formings might bend the sheet metal.
- Set of inserts composed of all elements showed on the side.

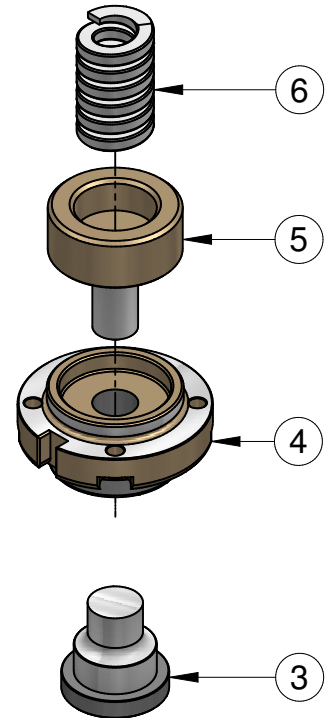

SET OF INSERTS M02			
POS.	DESCRIPTION	CODE	Q.ty
3	Lower Insert	FB09667123	1
4	Upper Insert	FB09247223.A43	1
5	Ejector	FB09550023.A43	1
6	Spring	A0903325.222	1

## UPPER INSERTS HOLDER

- Not included on the supply and not included on the price of the set of inserts.
- In case of order please specify one of the options indicated on the below table.

UPPER INSERTS HOLDER			
POS.	DESCRIPTION	CODE	✓
0	Not required	-	
1a	Adjustable round and shaped	FB08BA00	
1b	Adjustable round	FB09BA00	
1c	Fixed round and shaped	FB24BA00	
1d	Fixed round	FAZFBA00	

LOWER INSERTS HOLDER			
POS.	DESCRIPTION	CODE	✓
0	Not required	-	
2	Inserts Holder up to $\varnothing 10$	FAJ4BB00	





Title M02 08-1.0  
Extruded hole for M8 thread

Code : FB09237424.305

Station : B Thick Turret  
Date : 03/12/2012  
Telephone : 0039 0445 671015

Thickness :  $0.80 \pm 1.00$   
Rev : 0  
Fax : 0039 0445 671035

Forming : Up  
Rev. Date :  
E-Mail : sales@matrixtools.eu

<http://www.matrixtools.eu/catalogues/deformations>

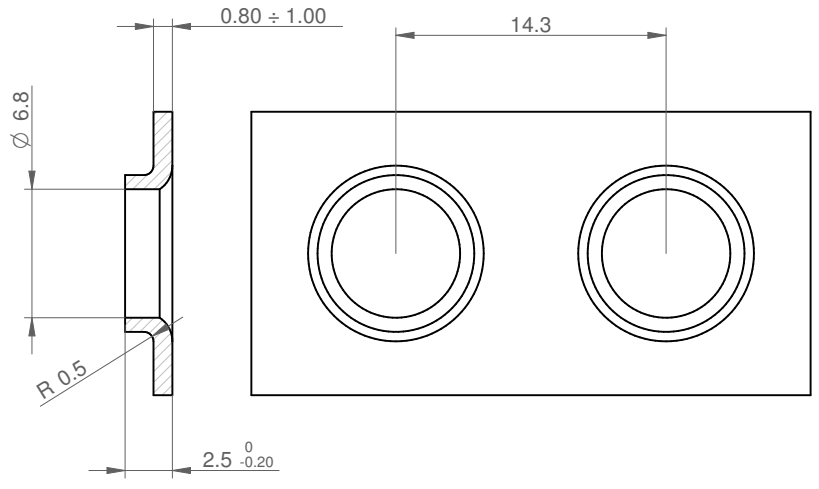

### SET OF INSERTS M02

- To be used on inserts Holder series WHITE and GREEN.
- This forming requires pre-pierce  $\varnothing 4,1 \pm 10\%$ .
- Multiple close formings might bend the sheet metal.
- Set of inserts composed of all elements showed on the side.

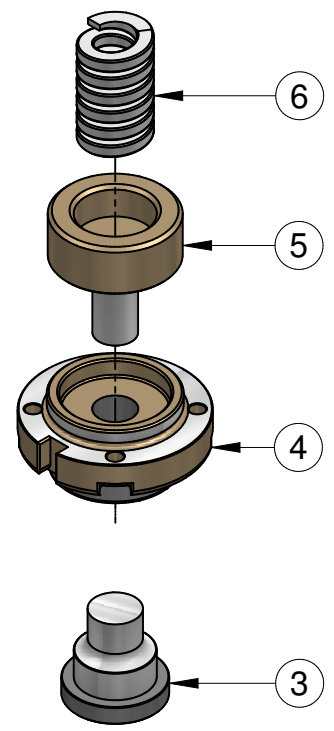

SET OF INSERTS M02			
POS.	DESCRIPTION	CODE	Q.ty
3	Lower Insert	FB09667124	1
4	Upper Insert	FB09247224.305	1
5	Ejector	FB09550024.305	1
6	Spring	A0903325.222	1

### UPPER INSERTS HOLDER

- Not included on the supply and not included on the price of the set of inserts.
- In case of order please specify one of the options indicated on the below table.

UPPER INSERTS HOLDER			
POS.	DESCRIPTION	CODE	✓
0	Not required	-	
1a	Adjustable round and shaped	FB08BA00	
1b	Adjustable round	FB09BA00	
1c	Fixed round and shaped	FB24BA00	
1d	Fixed round	FAZFBA00	

LOWER INSERTS HOLDER			
POS.	DESCRIPTION	CODE	✓
0	Not required	-	
2	Inserts Holder up to $\varnothing 10$	FAJ4BB00	





Title M02 08-1.2  
Extruded hole for M8 thread

Code : FB09237424.979

Station : B Thick Turret

Thickness :  $1.10 \div 1.30$

Forming : Up

Date : 03/12/2012

Rev : 0

Rev. Date :

Telephone : 0039 0445 671015

Fax : 0039 0445 671035

E-Mail : sales@matrixtools.eu

<http://www.matrixtools.eu/catalogues/deformations>

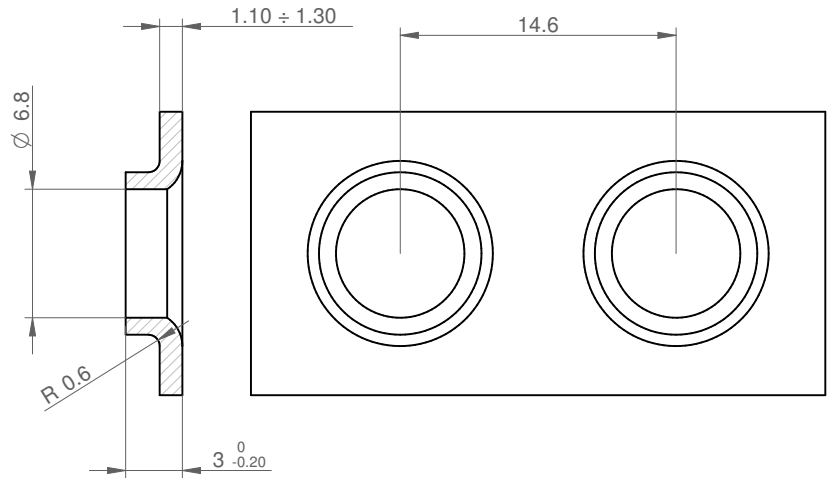

## SET OF INSERTS M02

- To be used on inserts Holder series WHITE and GREEN.
- This forming requires pre-pierce  $\varnothing 4,1 \pm 10\%$ .
- Multiple close formings might bend the sheet metal.
- Set of inserts composed of all elements showed on the side.

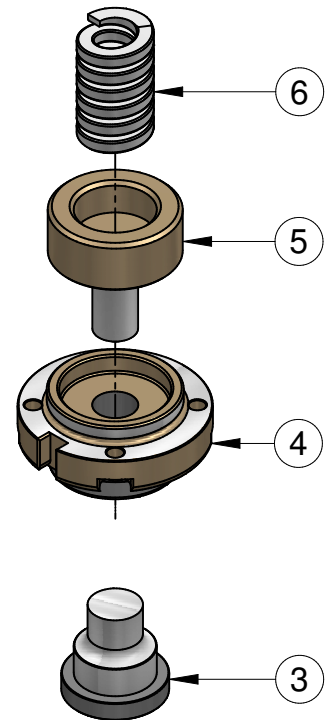

SET OF INSERTS M02			
POS.	DESCRIPTION	CODE	Q.ty
3	Lower Insert	FB09667124	1
4	Upper Insert	FB09247224.979	1
5	Ejector	FB09550024.979	1
6	Spring	A0903325.222	1

## UPPER INSERTS HOLDER

- Not included on the supply and not included on the price of the set of inserts.
- In case of order please specify one of the options indicated on the below table.

UPPER INSERTS HOLDER			
POS.	DESCRIPTION	CODE	✓
0	Not required	-	
1a	Adjustable round and shaped	FB08BA00	
1b	Adjustable round	FB09BA00	
1c	Fixed round and shaped	FB24BA00	
1d	Fixed round	FAZFBA00	

LOWER INSERTS HOLDER			
POS.	DESCRIPTION	CODE	✓
0	Not required	-	
2	Inserts Holder up to $\varnothing 10$	FAJ4BB00	





Title	M02 08-1.5 Extruded hole for M8 thread	Station :	B Thick Turret	Date :	03/12/2012	Telephone :	0039 0445 671015
		Thickness :	1.40 ÷ 1.60	Rev :	0	Fax :	0039 0445 671035
Code :	FB09237424.A43	Forming :	Up	Rev. Date :		E-Mail :	sales@matrixtools.eu

<http://www.matrixtools.eu/catalogues/deformations>

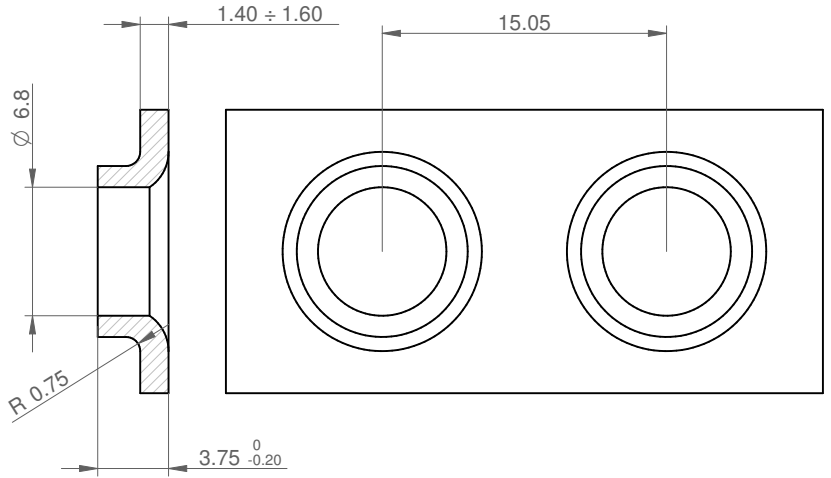

## SET OF INSERTS M02

- To be used on inserts Holder series WHITE and GREEN.
- This forming requires pre-pierce  $\varnothing 4,1 \pm 10\%$ .
- Multiple close formings might bend the sheet metal.
- Set of inserts composed of all elements showed on the side.

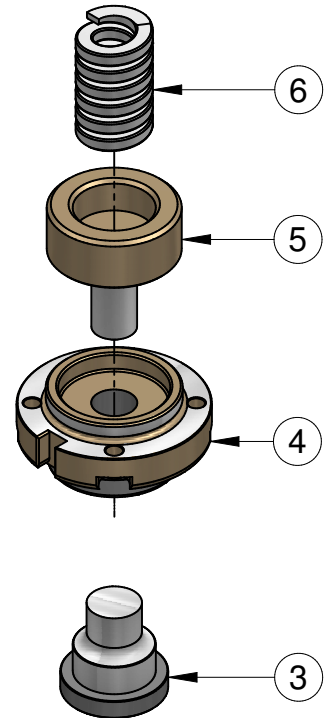

SET OF INSERTS M02			
POS.	DESCRIPTION	CODE	Q.ty
3	Lower Insert	FB09667124	1
4	Upper Insert	FB09247224.A43	1
5	Ejector	FB09550024.A43	1
6	Spring	A0903325.222	1

## UPPER INSERTS HOLDER

- Not included on the supply and not included on the price of the set of inserts.
- In case of order please specify one of the options indicated on the below table.

UPPER INSERTS HOLDER			
POS.	DESCRIPTION	CODE	✓
0	Not required	-	
1a	Adjustable round and shaped	FB08BA00	
1b	Adjustable round	FB09BA00	
1c	Fixed round and shaped	FB24BA00	
1d	Fixed round	FAZFBA00	

LOWER INSERTS HOLDER			
POS.	DESCRIPTION	CODE	✓
0	Not required	-	
2	Inserts Holder up to $\varnothing 10$	FAJ4BB00	







Title	M02 08-2.0	Station :	B Thick Turret	Date :	03/12/2012	Telephone :	0039 0445 671015
	Extruded hole for M8 thread	Thickness :	1.90 ÷ 2.10	Rev :	0	Fax :	0039 0445 671035
Code :	FB09237424.217	Forming :	Up	Rev. Date :		E-Mail :	sales@matrixtools.eu

<http://www.matrixtools.eu/catalogues/deformations>

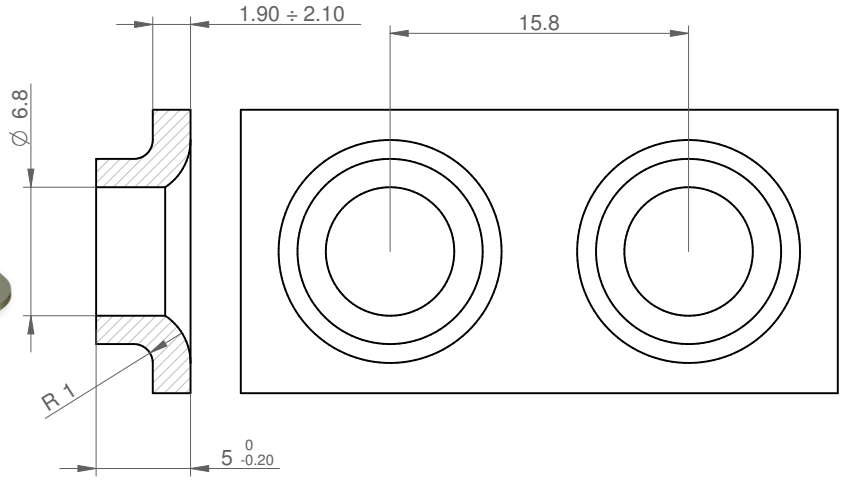

## SET OF INSERTS M02

- To be used on inserts Holder series WHITE and GREEN.
- This forming requires pre-pierce  $\varnothing 4,1 \pm 10\%$ .
- Multiple close formings might bend the sheet metal.
- Set of inserts composed of all elements showed on the side.

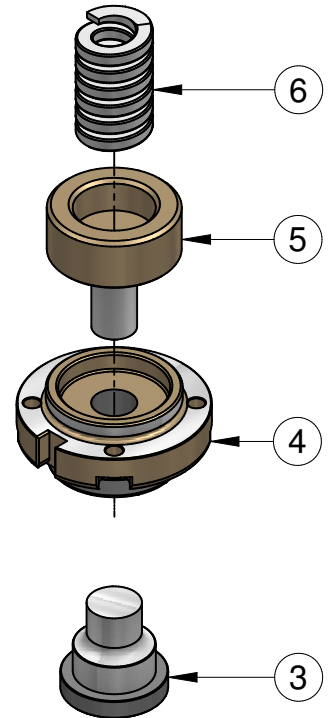

SET OF INSERTS M02			
POS.	DESCRIPTION	CODE	Q.ty
3	Lower Insert	FB09667124	1
4	Upper Insert	FB09247224.217	1
5	Ejector	FB09550024.217	1
6	Spring	A0903325.222	1

## UPPER INSERTS HOLDER

- Not included on the supply and not included on the price of the set of inserts.
- In case of order please specify one of the options indicated on the below table.

UPPER INSERTS HOLDER			
POS.	DESCRIPTION	CODE	✓
0	Not required	-	
1a	Adjustable round and shaped	FB08BA00	
1b	Adjustable round	FB09BA00	
1c	Fixed round and shaped	FB24BA00	
1d	Fixed round	FAZFBA00	

LOWER INSERTS HOLDER			
POS.	DESCRIPTION	CODE	✓
0	Not required	-	
2	Inserts Holder up to $\varnothing 10$	FAJ4BB00	





Title	M02 10-1.0 Extruded hole for M10 thread	Station :	B Thick Turret	Date :	03/12/2012	Telephone :	0039 0445 671015
		Thickness :	0.80 ÷ 1.00	Rev :	0	Fax :	0039 0445 671035
Code :	FB09237425.305	Forming :	Up	Rev. Date :		E-Mail :	sales@matrixtools.eu

<http://www.matrixtools.eu/catalogues/deformations>

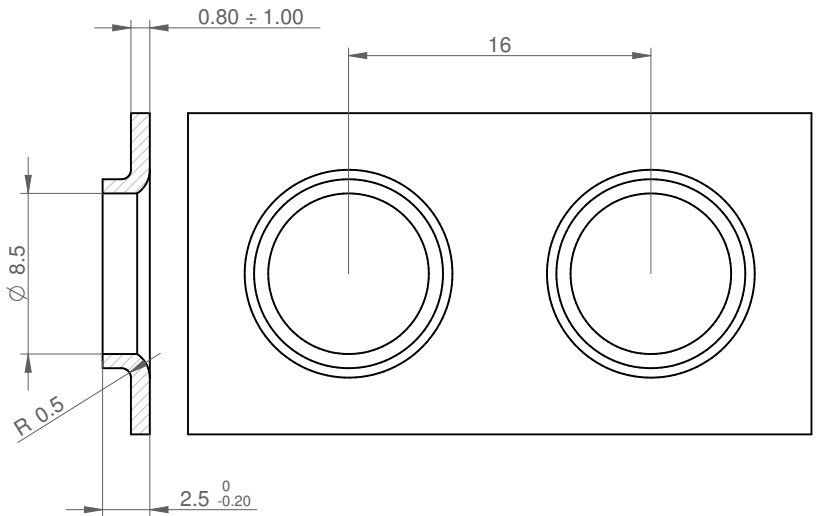

## SET OF INSERTS M02

- To be used on inserts Holder series WHITE and GREEN.
- This forming requires pre-pierce  $\varnothing 5,1 \pm 10\%$ .
- Multiple close formings might bend the sheet metal.
- Set of inserts composed of all elements showed on the side.

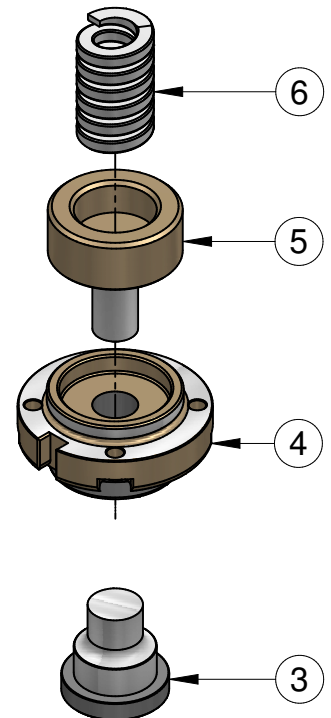

SET OF INSERTS M02			
POS.	DESCRIPTION	CODE	Q.ty
3	Lower Insert	FB09667125	1
4	Upper Insert	FB09247225.305	1
5	Ejector	FB09550025.305	1
6	Spring	A0903325.222	1

## UPPER INSERTS HOLDER

- Not included on the supply and not included on the price of the set of inserts.
- In case of order please specify one of the options indicated on the below table.

UPPER INSERTS HOLDER			
POS.	DESCRIPTION	CODE	✓
0	Not required	-	
1a	Adjustable round and shaped	FB08BA00	
1b	Adjustable round	FB09BA00	
1c	Fixed round and shaped	FB24BA00	
1d	Fixed round	FAZFBA00	

LOWER INSERTS HOLDER			
POS.	DESCRIPTION	CODE	✓
0	Not required	-	
2	Inserts Holder up to $\varnothing 10$	FAJ4BB00	





Title	M02 10-1.2 Extruded hole for M10 thread	Station :	B Thick Turret	Date :	03/12/2012	Telephone :	0039 0445 671015
		Thickness :	1.10 ÷ 1.30	Rev :	0	Fax :	0039 0445 671035
Code :	FB09237425.979	Forming :	Up	Rev. Date :		E-Mail :	sales@matrixtools.eu

<http://www.matrixtools.eu/catalogues/deformations>

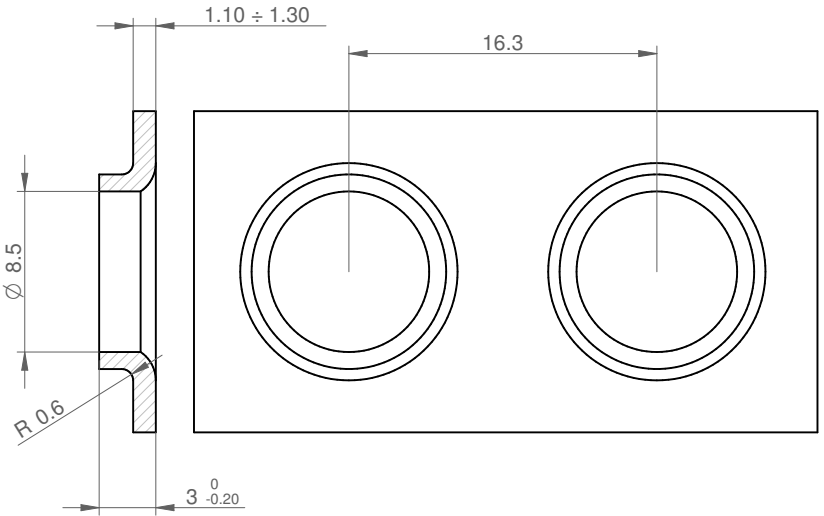

## SET OF INSERTS M02

- To be used on inserts Holder series WHITE and GREEN.
- This forming requires pre-pierce  $\varnothing 5,1 \pm 10\%$ .
- Multiple close formings might bend the sheet metal.
- Set of inserts composed of all elements showed on the side.

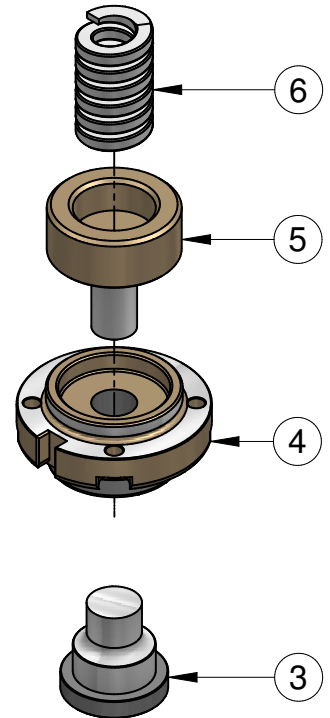

SET OF INSERTS M02			
POS.	DESCRIPTION	CODE	Q.ty
3	Lower Insert	FB09667125	1
4	Upper Insert	FB09247225.979	1
5	Ejector	FB09550025.979	1
6	Spring	A0903325.222	1

## UPPER INSERTS HOLDER

- Not included on the supply and not included on the price of the set of inserts.
- In case of order please specify one of the options indicated on the below table.

UPPER INSERTS HOLDER			
POS.	DESCRIPTION	CODE	✓
0	Not required	-	
1a	Adjustable round and shaped	FB08BA00	
1b	Adjustable round	FB09BA00	
1c	Fixed round and shaped	FB24BA00	
1d	Fixed round	FAZFBA00	

LOWER INSERTS HOLDER			
POS.	DESCRIPTION	CODE	✓
0	Not required	-	
2	Inserts Holder up to $\varnothing 10$	FAJ4BB00	





Title	M02 10-1.5 Extruded hole for M10 thread	Station :	B Thick Turret	Date :	03/12/2012	Telephone :	0039 0445 671015
		Thickness :	1.40 ÷ 1.60	Rev :	0	Fax :	0039 0445 671035
Code :	FB09237425.A43	Forming :	Up	Rev. Date :		E-Mail :	sales@matrixtools.eu

<http://www.matrixtools.eu/catalogues/deformations>

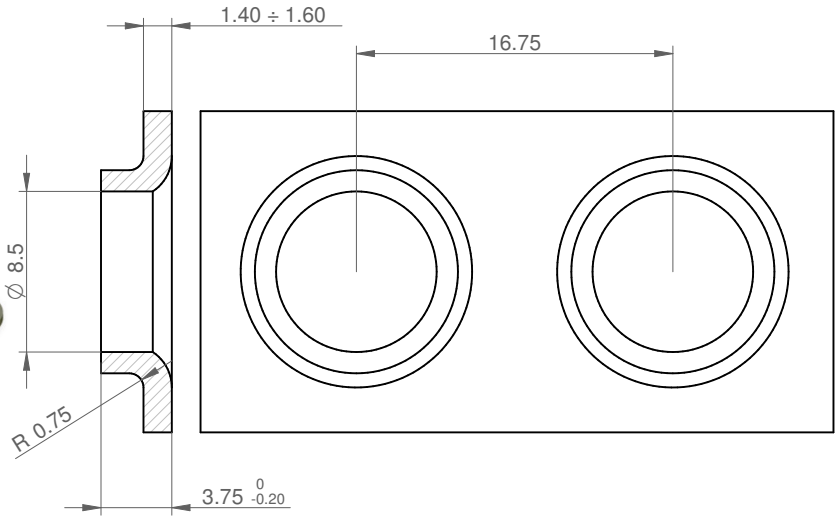

## SET OF INSERTS M02

- To be used on inserts Holder series WHITE and GREEN.
- This forming requires pre-pierce  $\varnothing 5,1 \pm 10\%$ .
- Multiple close formings might bend the sheet metal.
- Set of inserts composed of all elements showed on the side.

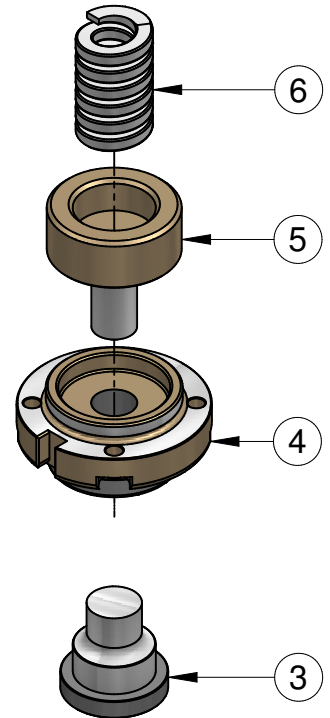

SET OF INSERTS M02			
POS.	DESCRIPTION	CODE	Q.ty
3	Lower Insert	FB09667125	1
4	Upper Insert	FB09247225.A43	1
5	Ejector	FB09550025.A43	1
6	Spring	A0903325.222	1

## UPPER INSERTS HOLDER

- Not included on the supply and not included on the price of the set of inserts.
- In case of order please specify one of the options indicated on the below table.

UPPER INSERTS HOLDER			
POS.	DESCRIPTION	CODE	✓
0	Not required	-	
1a	Adjustable round and shaped	FB08BA00	
1b	Adjustable round	FB09BA00	
1c	Fixed round and shaped	FB24BA00	
1d	Fixed round	FAZFBA00	

LOWER INSERTS HOLDER			
POS.	DESCRIPTION	CODE	✓
0	Not required	-	
2	Inserts Holder up to $\varnothing 10$	FAJ4BB00	





Title	M02 10-2.0 Extruded hole for M10 thread	Station :	B Thick Turret	Date :	03/12/2012	Telephone :	0039 0445 671015
		Thickness :	1.90 ÷ 2.10	Rev :	0	Fax :	0039 0445 671035
Code :	FB09237425.217	Forming :	Up	Rev. Date :		E-Mail :	sales@matrixtools.eu

<http://www.matrixtools.eu/catalogues/deformations>

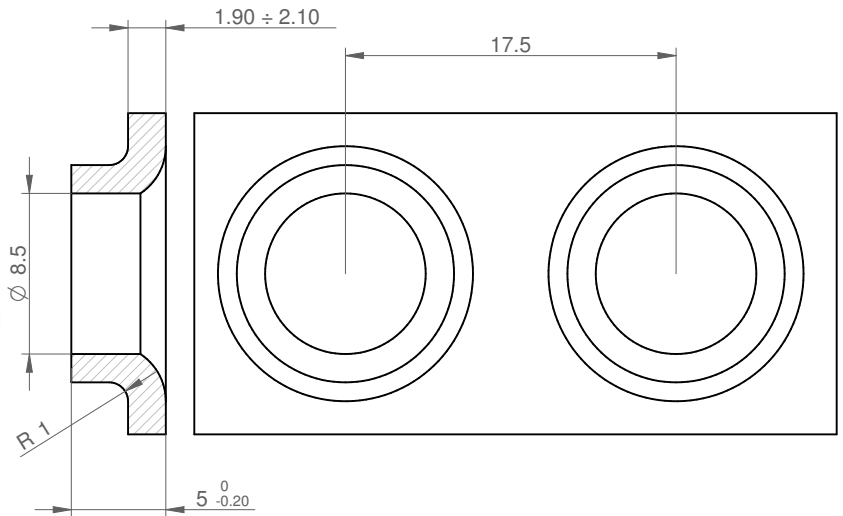

## SET OF INSERTS M02

- To be used on inserts Holder series WHITE and GREEN.
- This forming requires pre-pierce  $\varnothing 5,1 \pm 10\%$ .
- Multiple close formings might bend the sheet metal.
- Set of inserts composed of all elements showed on the side.

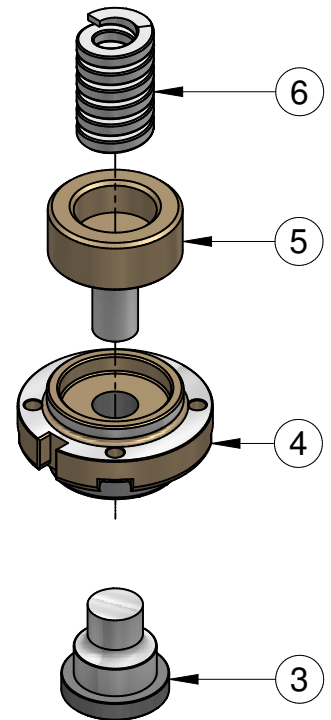

SET OF INSERTS M02			
POS.	DESCRIPTION	CODE	Q.ty
3	Lower Insert	FB09667125	1
4	Upper Insert	FB09247225.217	1
5	Ejector	FB09550025.217	1
6	Spring	A0903325.222	1

## UPPER INSERTS HOLDER

- Not included on the supply and not included on the price of the set of inserts.
- In case of order please specify one of the options indicated on the below table.

UPPER INSERTS HOLDER			
POS.	DESCRIPTION	CODE	✓
0	Not required	-	
1a	Adjustable round and shaped	FB08BA00	
1b	Adjustable round	FB09BA00	
1c	Fixed round and shaped	FB24BA00	
1d	Fixed round	FAZFBA00	

LOWER INSERTS HOLDER			
POS.	DESCRIPTION	CODE	✓
0	Not required	-	
2	Inserts Holder up to $\varnothing 10$	FAJ4BB00	





Title	M04 04-1.0 Round Countersink for M4 screw	Station :	B Thick Turret	Date :	12/12/2012	Telephone :	0039 0445 671015
		Thickness :	0.80 ÷ 1.20	Rev :	0	Fax :	0039 0445 671035
Code :	FB09237239.305	Forming :	Up	Rev. Date :		E-Mail :	sales@matrixtools.eu

<http://www.matrixtools.eu/catalogues/deformations>

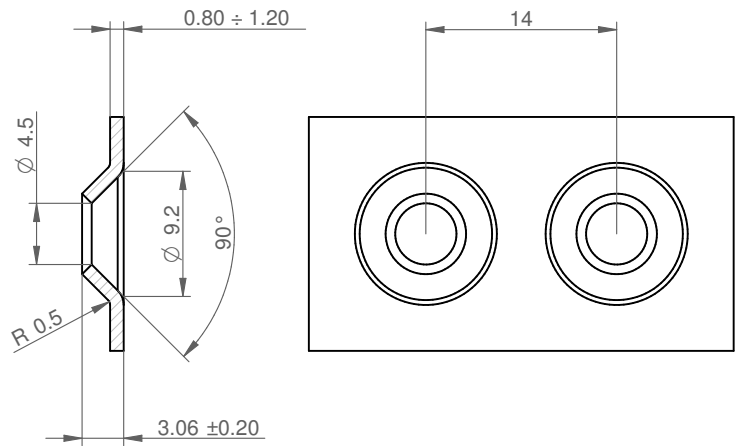
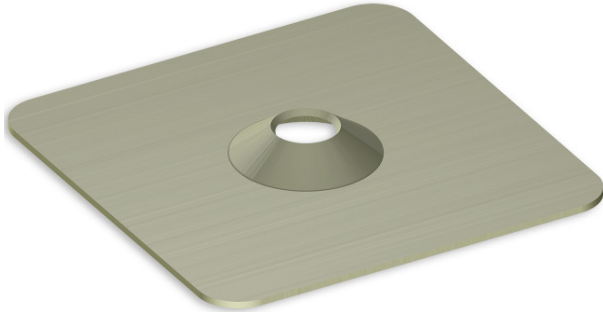

## SET OF INSERTS M04

- To be used on inserts Holder series WHITE and GREEN.
- This forming requires pre-pierce  $\varnothing 3,66 \pm 10\%$ .
- Multiple close formings might bend the sheet metal.
- Set of inserts composed of all elements showed on the side.

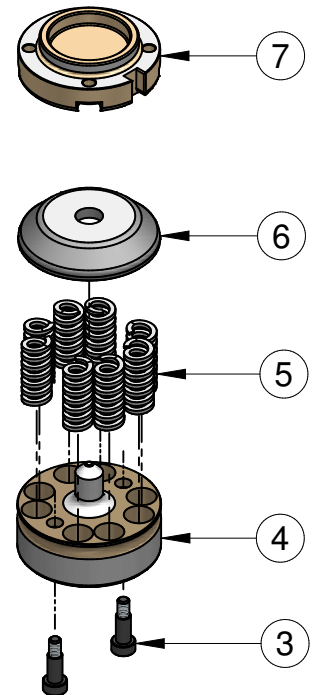

SET OF INSERTS M04			
POS.	DESCRIPTION	CODE	Q.ty
3	Screw	A0116805.019	2
4	Lower insert	FB09176939	1
5	Spring	A0903326.189	8
6	Stripper	FB09036939	1
7	Upper insert	FB09247239.305	1

## UPPER INSERTS HOLDER

- Not included on the supply and not included on the price of the set of inserts.
- In case of order please specify one of the options indicated on the below table.



UPPER INSERTS HOLDER			
POS.	DESCRIPTION	CODE	✓
0	Not required	-	
1a	Adjustable round and shaped	FB08BA00	
1b	Adjustable round	FB09BA00	
1c	Fixed round and shaped	FB24BA00	
1d	Fixed round	FAZFA00	





Title	M04 04-1.7 Round Countersink for M4 screw	Station :	B Thick Turret	Date :	12/12/2012	Telephone :	0039 0445 671015
		Thickness :	1.50 ÷ 1.90	Rev :	0	Fax :	0039 0445 671035
Code :	FB09237239.BP5	Forming :	Up	Rev. Date :		E-Mail :	sales@matrixtools.eu

<http://www.matrixtools.eu/catalogues/deformations>

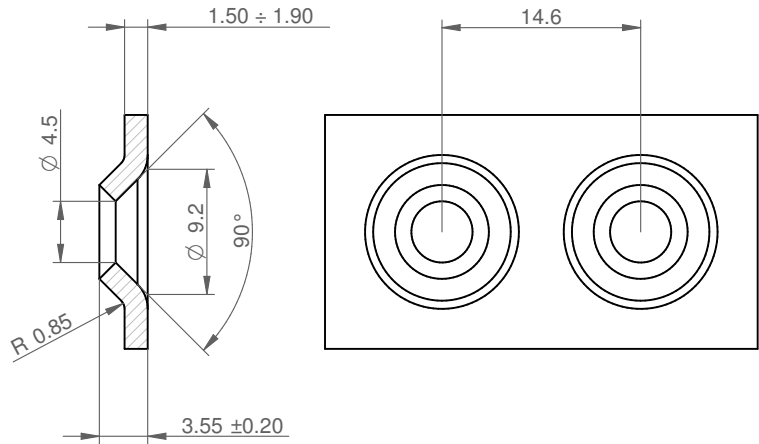
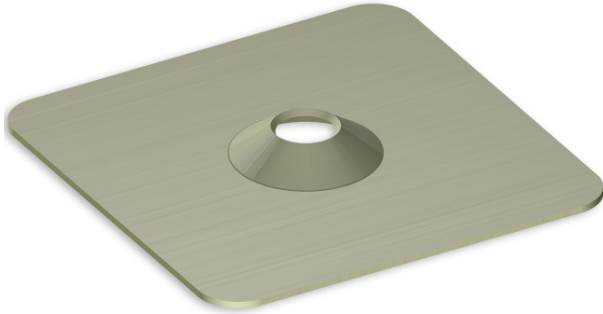

## SET OF INSERTS M04

- To be used on inserts Holder series WHITE and GREEN.
- This forming requires pre-pierce  $\varnothing 4,43 \pm 10\%$ .
- Multiple close formings might bend the sheet metal.
- Set of inserts composed of all elements showed on the side.

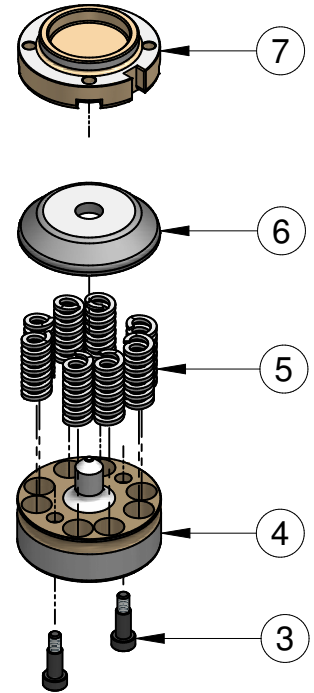

SET OF INSERTS M04			
POS.	DESCRIPTION	CODE	Q.ty
3	Screw	A0116805.019	2
4	Lower insert	FB09176939	1
5	Spring	A0903326.189	8
6	Stripper	FB09036939	1
7	Upper insert	FB09247239.BP5	1

## UPPER INSERTS HOLDER

- Not included on the supply and not included on the price of the set of inserts.
- In case of order please specify one of the options indicated on the below table.

UPPER INSERTS HOLDER			
POS.	DESCRIPTION	CODE	✓
0	Not required	-	
1a	Adjustable round and shaped	FB08BA00	
1b	Adjustable round	FB09BA00	
1c	Fixed round and shaped	FB24BA00	
1d	Fixed round	FAZFBA00	





Title	M04 04-2.2 Round Countersink for M4 screw	Station :	B Thick Turret	Date :	12/12/2012	Telephone :	0039 0445 671015
		Thickness :	2.00 ÷ 2.50	Rev :	0	Fax :	0039 0445 671035
Code :	FB09237239.844	Forming :	Up	Rev. Date :		E-Mail :	sales@matrixtools.eu

<http://www.matrixtools.eu/catalogues/deformations>

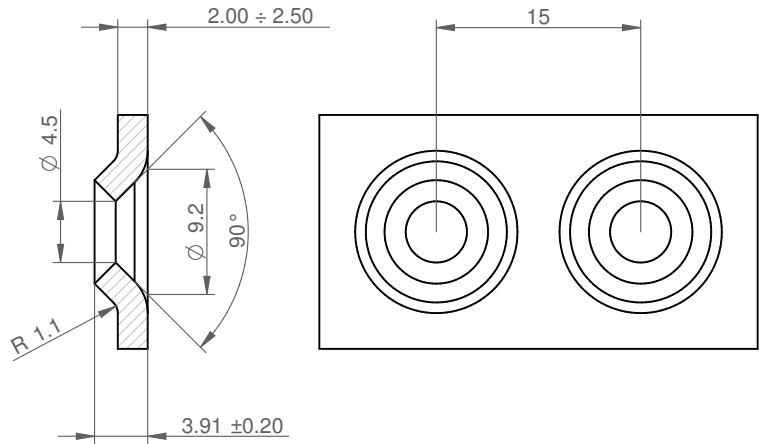
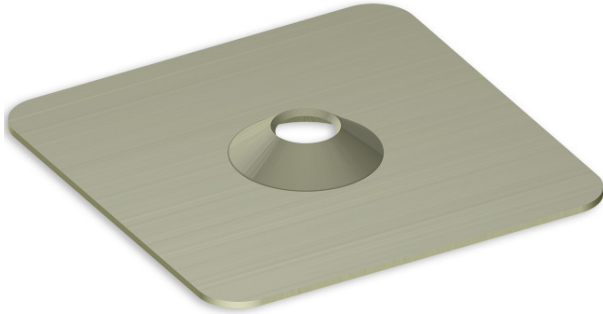

## SET OF INSERTS M04

- To be used on inserts Holder series WHITE and GREEN.
- This forming requires pre-pierce  $\varnothing 4,99 \pm 10\%$ .
- Multiple close formings might bend the sheet metal.
- Set of inserts composed of all elements showed on the side.

SET OF INSERTS M04			
POS.	DESCRIPTION	CODE	Q.ty
3	Screw	A0116805.019	2
4	Lower insert	FB09176939	1
5	Spring	A0903326.189	8
6	Stripper	FB09036939	1
7	Upper insert	FB09247239.844	1

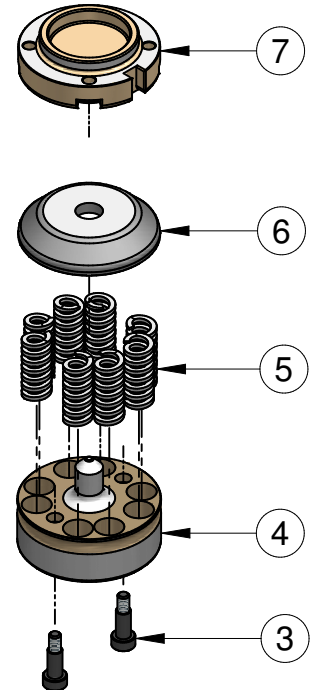

## UPPER INSERTS HOLDER

- Not included on the supply and not included on the price of the set of inserts.
- In case of order please specify one of the options indicated on the below table.

UPPER INSERTS HOLDER			
POS.	DESCRIPTION	CODE	✓
0	Not required	-	
1a	Adjustable round and shaped	FB08BA00	
1b	Adjustable round	FB09BA00	
1c	Fixed round and shaped	FB24BA00	
1d	Fixed round	FAZFBAA0	





Title	M04 05-1.0 Round Countersink for M5 screw	Station :	B Thick Turret	Date :	20/12/2012	Telephone :	0039 0445 671015
		Thickness :	0.80 ÷ 1.20	Rev :	0	Fax :	0039 0445 671035
Code :	FB09237240.305	Forming :	Up	Rev. Date :		E-Mail :	sales@matrixtools.eu

<http://www.matrixtools.eu/catalogues/deformations>

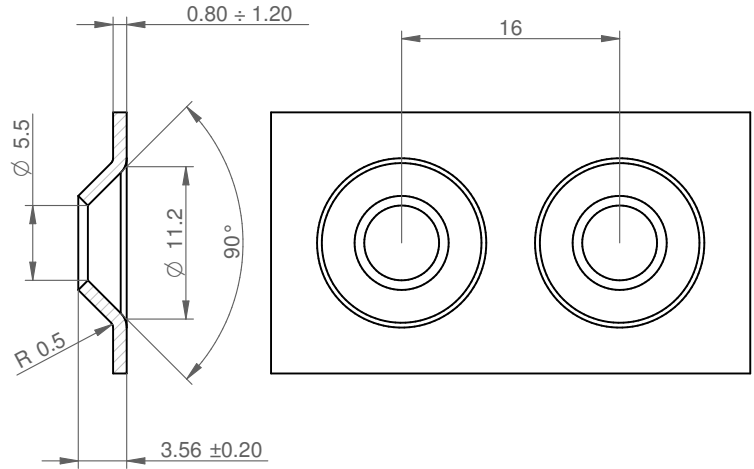
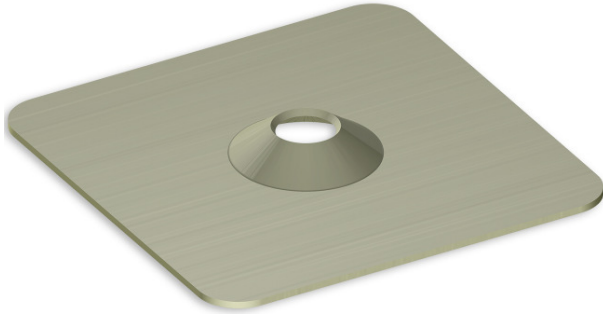

## SET OF INSERTS M04

- To be used on inserts Holder series WHITE and GREEN.
- This forming requires pre-pierce  $\varnothing 4,25 \pm 10\%$ .
- Multiple close formings might bend the sheet metal.
- Set of inserts composed of all elements showed on the side.

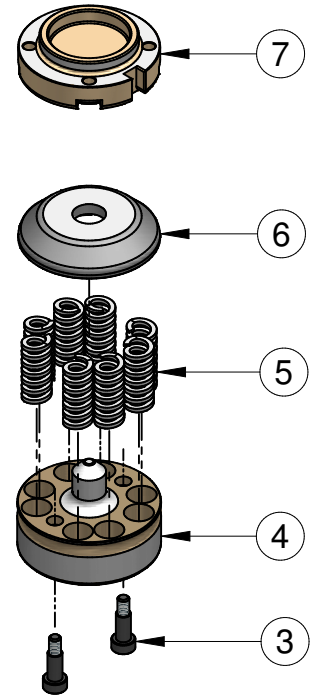

SET OF INSERTS M04			
POS.	DESCRIPTION	CODE	Q.ty
3	Screw	A0116805.019	2
4	Lower insert	FB09176940	1
5	Spring	A0903326.189	8
6	Stripper	FB09036940	1
7	Upper insert	FB09247240.305	1

## UPPER INSERTS HOLDER

- Not included on the supply and not included on the price of the set of inserts.
- In case of order please specify one of the options indicated on the below table.

UPPER INSERTS HOLDER			
POS.	DESCRIPTION	CODE	✓
0	Not required	-	
1a	Adjustable round and shaped	FB08BA00	
1b	Adjustable round	FB09BA00	
1c	Fixed round and shaped	FB24BA00	
1d	Fixed round	FAZFA00	





Title	M04 05-1.7 Round Countersink for M5 screw	Station :	B Thick Turret	Date :	20/12/2012	Telephone :	0039 0445 671015
		Thickness :	1.50 ÷ 1.90	Rev :	0	Fax :	0039 0445 671035
Code :	FB09237240.BP5	Forming :	Up	Rev. Date :		E-Mail :	sales@matrixtools.eu

<http://www.matrixtools.eu/catalogues/deformations>

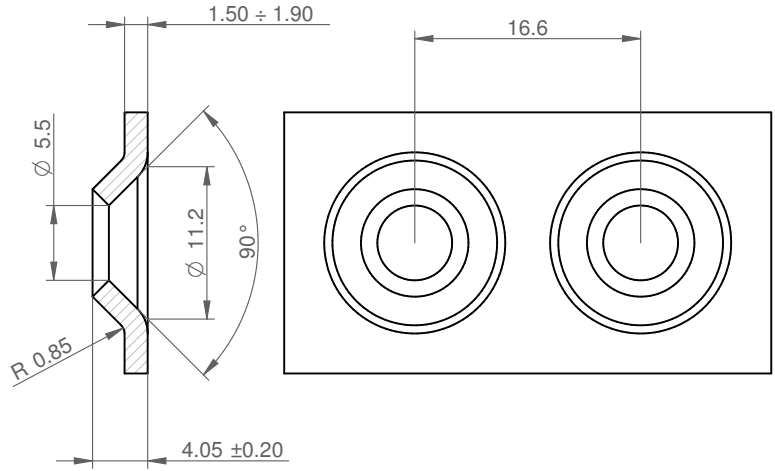
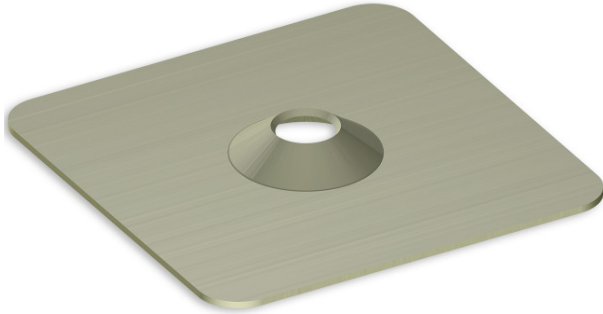

## SET OF INSERTS M04

- To be used on inserts Holder series WHITE and GREEN.
- This forming requires pre-pierce  $\varnothing 5,02 \pm 10\%$ .
- Multiple close formings might bend the sheet metal.
- Set of inserts composed of all elements showed on the side.

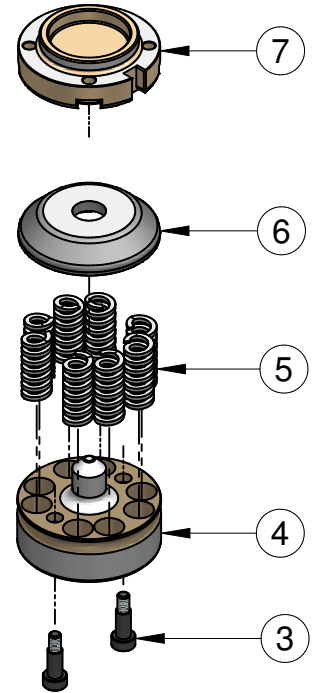

SET OF INSERTS M04			
POS.	DESCRIPTION	CODE	Q.ty
3	Screw	A0116805.019	2
4	Lower insert	FB09176940	1
5	Spring	A0903326.189	8
6	Stripper	FB09036940	1
7	Upper insert	FB09247240.BP5	1

## UPPER INSERTS HOLDER

- Not included on the supply and not included on the price of the set of inserts.
- In case of order please specify one of the options indicated on the below table.



UPPER INSERTS HOLDER			
POS.	DESCRIPTION	CODE	✓
0	Not required	-	
1a	Adjustable round and shaped	FB08BA00	
1b	Adjustable round	FB09BA00	
1c	Fixed round and shaped	FB24BA00	
1d	Fixed round	FAZFBA00	



Title	M04 05-2.2	Station :	B Thick Turret	Date :	21/12/2012	Telephone :	0039 0445 671015
	Round Countersink for M5 screw	Thickness :	2.00 ÷ 2.50	Rev :	0	Fax :	0039 0445 671035
Code :	FB09237240.844	Forming :	Up	Rev. Date :		E-Mail :	sales@matrixtools.eu

<http://www.matrixtools.eu/catalogues/deformations>

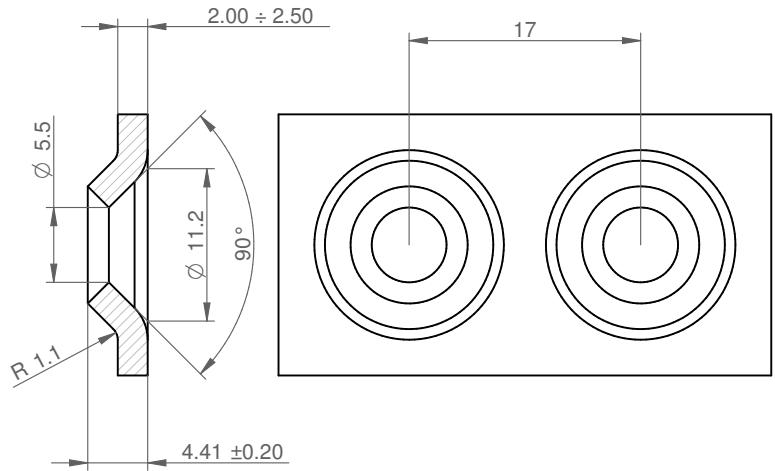
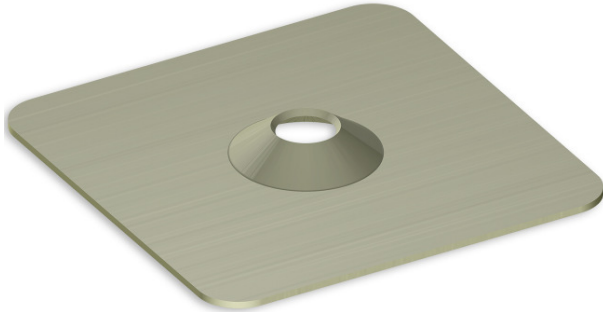

## SET OF INSERTS M04

- To be used on inserts Holder series WHITE and GREEN.
- This forming requires pre-pierce  $\varnothing 5,57 \pm 10\%$ .
- Multiple close formings might bend the sheet metal.
- Set of inserts composed of all elements showed on the side.

SET OF INSERTS M04			
POS.	DESCRIPTION	CODE	Q.ty
3	Screw	A0116805.019	2
4	Lower insert	FB09176940	1
5	Spring	A0903326.189	8
6	Stripper	FB09036940	1
7	Upper insert	FB09247240.844	1

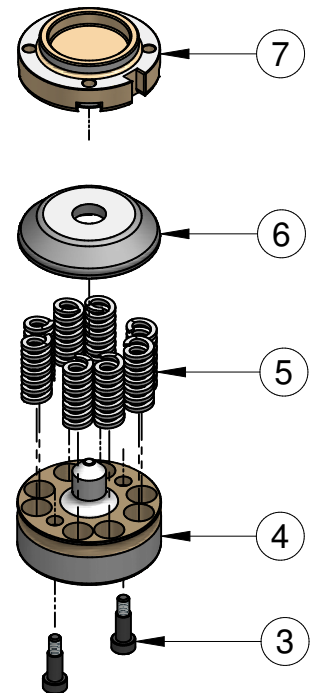

## UPPER INSERTS HOLDER

- Not included on the supply and not included on the price of the set of inserts.
- In case of order please specify one of the options indicated on the below table.

UPPER INSERTS HOLDER			
POS.	DESCRIPTION	CODE	✓
0	Not required	-	
1a	Adjustable round and shaped	FB08BA00	
1b	Adjustable round	FB09BA00	
1c	Fixed round and shaped	FB24BA00	
1d	Fixed round	FAZFBFA00	





Title	M04 06-1.0 Round Countersink for M6 screw	Station :	B Thick Turret	Date :	20/12/2012	Telephone :	0039 0445 671015
		Thickness :	0.80 ÷ 1.20	Rev :	0	Fax :	0039 0445 671035
Code :	FB09237241.305	Forming :	Up	Rev. Date :		E-Mail :	sales@matrixtools.eu

<http://www.matrixtools.eu/catalogues/deformations>

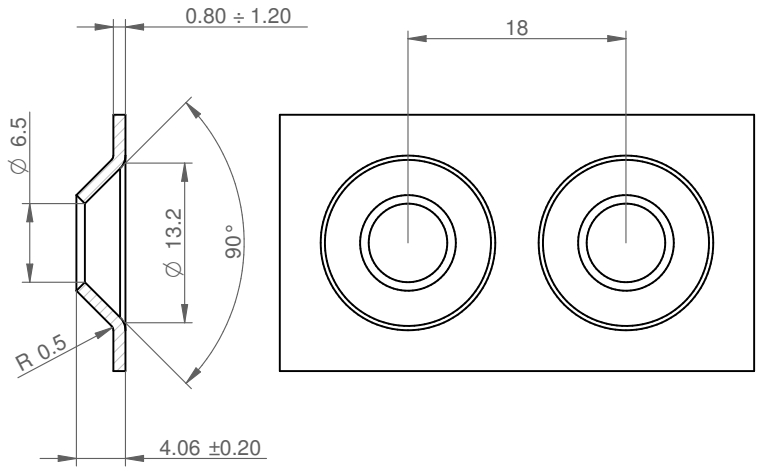
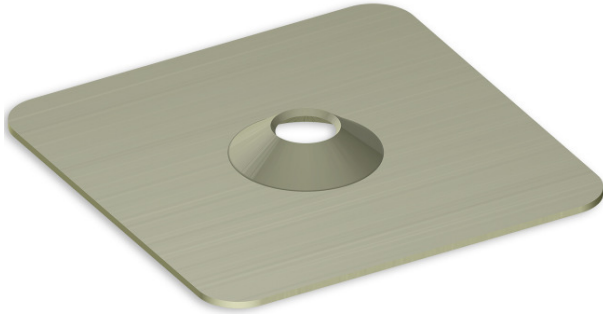

## SET OF INSERTS M04

- To be used on inserts Holder series WHITE and GREEN.
- This forming requires pre-pierce  $\varnothing 4,83 \pm 10\%$ .
- Multiple close formings might bend the sheet metal.
- Set of inserts composed of all elements showed on the side.

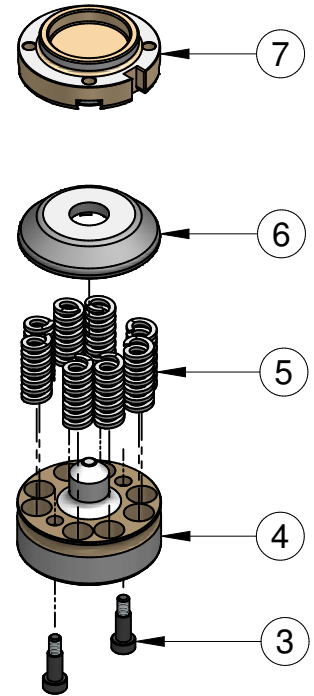

SET OF INSERTS M04			
POS.	DESCRIPTION	CODE	Q.ty
3	Screw	A0116805.019	2
4	Lower insert	FB09176941	1
5	Spring	A0903326.189	8
6	Stripper	FB09036941	1
7	Upper insert	FB09247241.305	1

## UPPER INSERTS HOLDER

- Not included on the supply and not included on the price of the set of inserts.
- In case of order please specify one of the options indicated on the below table.



UPPER INSERTS HOLDER			
POS.	DESCRIPTION	CODE	✓
0	Not required	-	
1a	Adjustable round and shaped	FB08BA00	
1b	Adjustable round	FB09BA00	
1c	Fixed round and shaped	FB24BA00	
1d	Fixed round	FAZFBA00	





Title	M04 06-1.7 Round Countersink for M6 screw	Station :	B Thick Turret	Date :	20/12/2012	Telephone :	0039 0445 671015
		Thickness :	1.50 ÷ 1.90	Rev :	0	Fax :	0039 0445 671035
Code :	FB09237241.BP5	Forming :	Up	Rev. Date :		E-Mail :	sales@matrixtools.eu

<http://www.matrixtools.eu/catalogues/deformations>

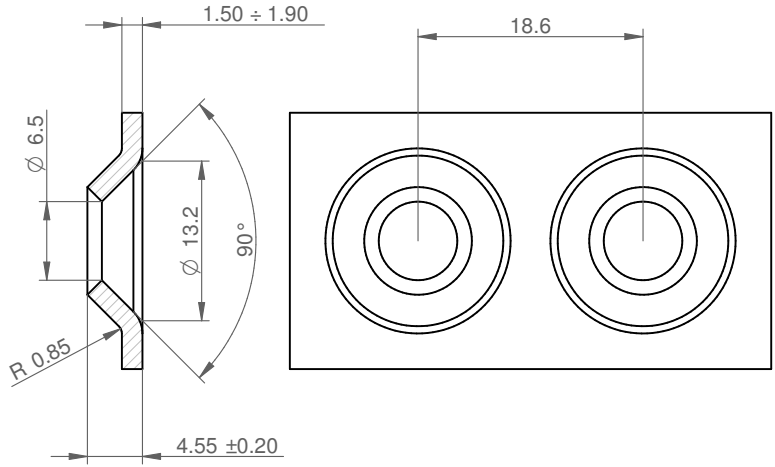

## SET OF INSERTS M04

- To be used on inserts Holder series WHITE and GREEN.
- This forming requires pre-pierce  $\varnothing 5,61 \pm 10\%$ .
- Multiple close formings might bend the sheet metal.
- Set of inserts composed of all elements showed on the side.

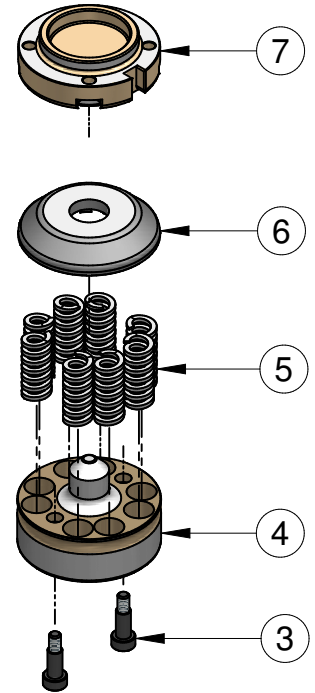

SET OF INSERTS M04			
POS.	DESCRIPTION	CODE	Q.ty
3	Screw	A0116805.019	2
4	Lower insert	FB09176941	1
5	Spring	A0903326.189	8
6	Stripper	FB09036941	1
7	Upper insert	FB09247241.BP5	1

## UPPER INSERTS HOLDER

- Not included on the supply and not included on the price of the set of inserts.
- In case of order please specify one of the options indicated on the below table.



UPPER INSERTS HOLDER			
POS.	DESCRIPTION	CODE	✓
0	Not required	-	
1a	Adjustable round and shaped	FB08BA00	
1b	Adjustable round	FB09BA00	
1c	Fixed round and shaped	FB24BA00	
1d	Fixed round	FAZFBA00	



Title	M04 06-2.2	Station :	B Thick Turret	Date :	21/12/2012	Telephone :	0039 0445 671015
	Round Countersink for M6 screw	Thickness :	2.00 ÷ 2.50	Rev :	0	Fax :	0039 0445 671035
Code :	FB09237241.844	Forming :	Up	Rev. Date :		E-Mail :	sales@matrixtools.eu

<http://www.matrixtools.eu/catalogues/deformations>

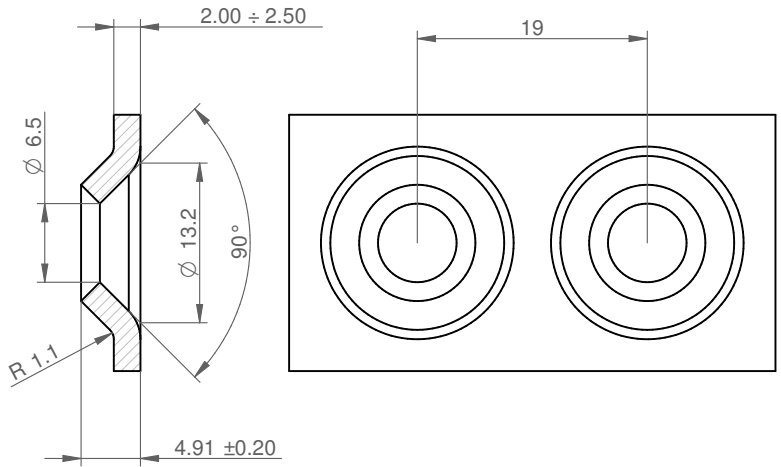
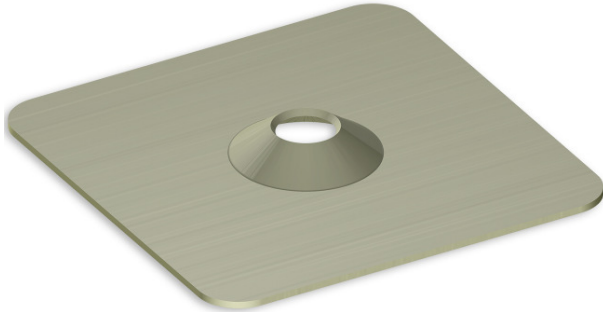

## SET OF INSERTS M04

- To be used on inserts Holder series WHITE and GREEN.
- This forming requires pre-pierce  $\phi 6,16 \pm 10\%$ .
- Multiple close formings might bend the sheet metal.
- Set of inserts composed of all elements showed on the side.

SET OF INSERTS M04			
POS.	DESCRIPTION	CODE	Q.ty
3	Screw	A0116805.019	2
4	Lower insert	FB09176941	1
5	Spring	A0903326.189	8
6	Stripper	FB09036941	1
7	Upper insert	FB09247241.844	1

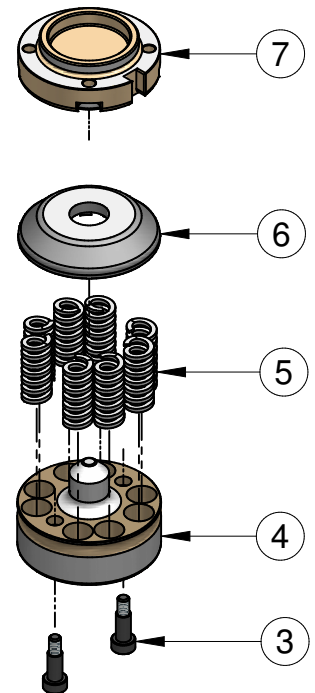

## UPPER INSERTS HOLDER

- Not included on the supply and not included on the price of the set of inserts.
- In case of order please specify one of the options indicated on the below table.

UPPER INSERTS HOLDER			
POS.	DESCRIPTION	CODE	✓
0	Not required	-	
1a	Adjustable round and shaped	FB08BA00	
1b	Adjustable round	FB09BA00	
1c	Fixed round and shaped	FB24BA00	
1d	Fixed round	FAZFBAA0	





Title	M04 08-1.0 Round Countersink for M8 screw	Station :	B Thick Turret	Date :	20/12/2012	Telephone :	0039 0445 671015
		Thickness :	0.80 ÷ 1.20	Rev :	0	Fax :	0039 0445 671035
Code :	FB09237242.305	Forming :	Up	Rev. Date :		E-Mail :	sales@matrixtools.eu

<http://www.matrixtools.eu/catalogues/deformations>

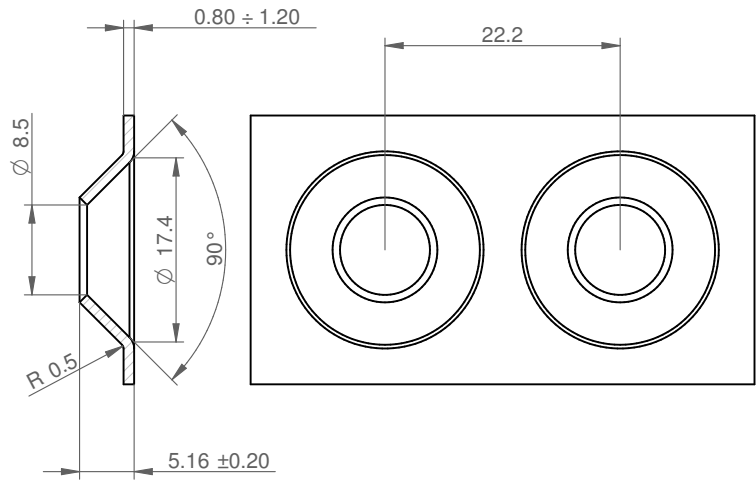
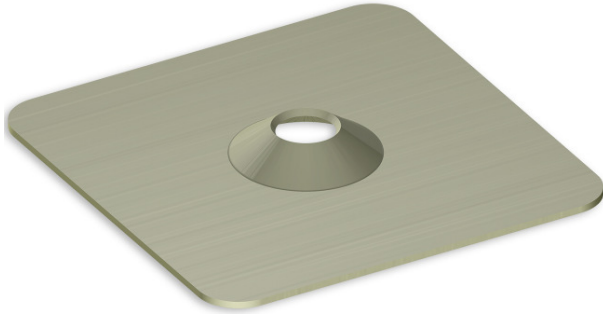

## SET OF INSERTS M04

- To be used on inserts Holder series WHITE and GREEN.
- This forming requires pre-pierce  $\varnothing 5,92 \pm 10\%$ .
- Multiple close formings might bend the sheet metal.
- Set of inserts composed of all elements showed on the side.

SET OF INSERTS M04			
POS.	DESCRIPTION	CODE	Q.ty
3	Screw	A0116805.019	2
4	Lower insert	FB09176942	1
5	Spring	A0903326.189	8
6	Stripper	FB09036942	1
7	Upper insert	FB09247242.305	1

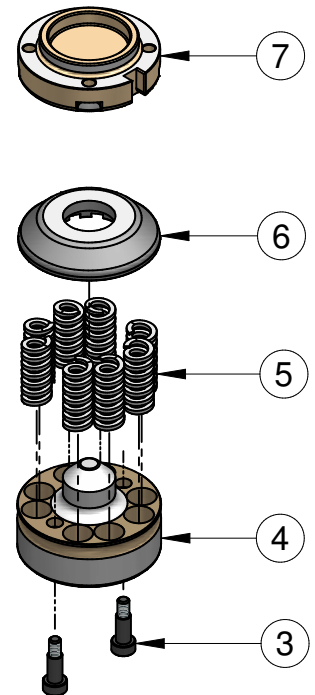

## UPPER INSERTS HOLDER

- Not included on the supply and not included on the price of the set of inserts.
- In case of order please specify one of the options indicated on the below table.

UPPER INSERTS HOLDER			
POS.	DESCRIPTION	CODE	✓
0	Not required	-	
1a	Adjustable round and shaped	FB08BA00	
1b	Adjustable round	FB09BA00	
1c	Fixed round and shaped	FB24BA00	
1d	Fixed round	FAZFBAA0	





Title	M04 08-1.7 Round Countersink for M8 screw	Station :	B Thick Turret	Date :	20/12/2012	Telephone :	0039 0445 671015
		Thickness :	1.50 ÷ 1.90	Rev :	0	Fax :	0039 0445 671035
Code :	FB09237242.BP5	Forming :	Up	Rev. Date :		E-Mail :	sales@matrixtools.eu

<http://www.matrixtools.eu/catalogues/deformations>

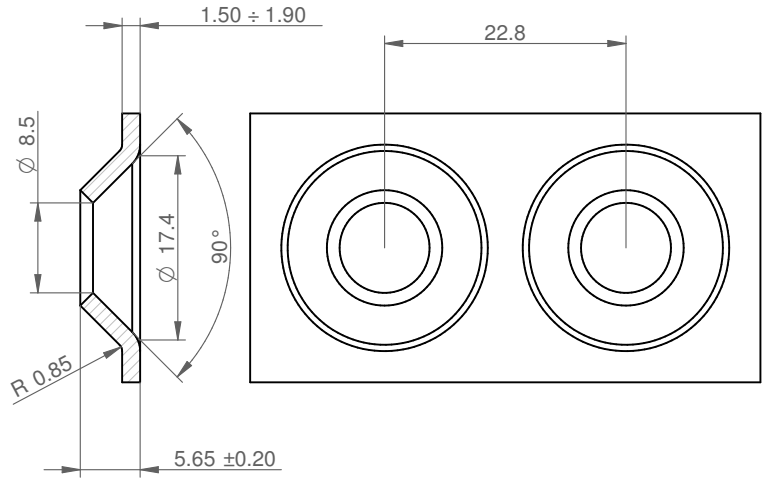
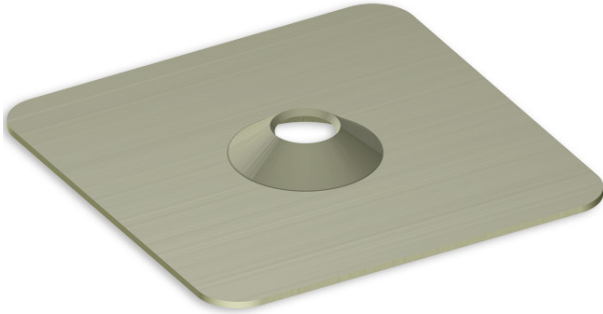

## SET OF INSERTS M04

- To be used on inserts Holder series WHITE and GREEN.
- This forming requires pre-pierce  $\varnothing 6,7 \pm 10\%$ .
- Multiple close formings might bend the sheet metal.
- Set of inserts composed of all elements showed on the side.

SET OF INSERTS M04			
POS.	DESCRIPTION	CODE	Q.ty
3	Screw	A0116805.019	2
4	Lower insert	FB09176942	1
5	Spring	A0903326.189	8
6	Stripper	FB09036942	1
7	Upper insert	FB09247242.BP5	1

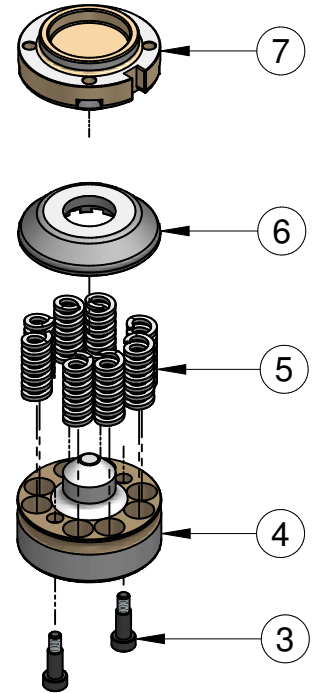

## UPPER INSERTS HOLDER

- Not included on the supply and not included on the price of the set of inserts.
- In case of order please specify one of the options indicated on the below table.

UPPER INSERTS HOLDER			
POS.	DESCRIPTION	CODE	✓
0	Not required	-	
1a	Adjustable round and shaped	FB08BA00	
1b	Adjustable round	FB09BA00	
1c	Fixed round and shaped	FB24BA00	
1d	Fixed round	FAZFBAA00	





Title	M04 08-2.2	Station :	B Thick Turret	Date :	21/12/2012	0039 0445 671015	
	Round Countersink for M8 screw	Thickness :	2.00 ÷ 2.50	Rev :	0		Fax :
Code :	FB09237242.844	Forming :	Up	Rev. Date :		E-Mail :	sales@matrixtools.eu

<http://www.matrixtools.eu/catalogues/deformations>

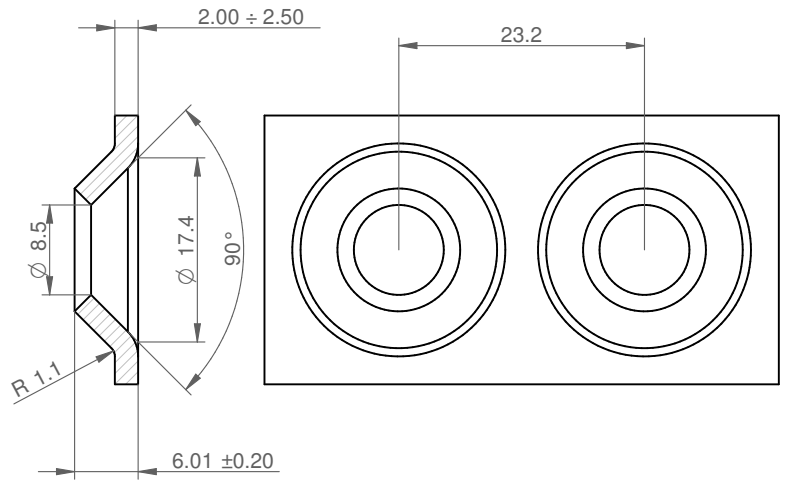
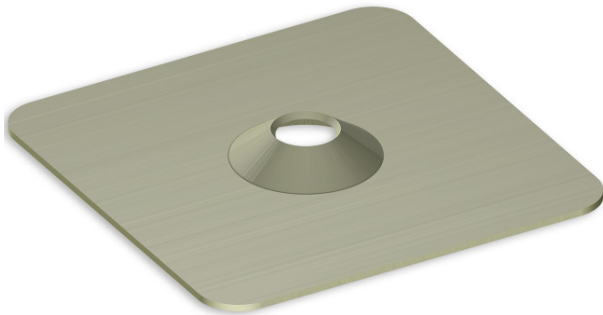

## SET OF INSERTS M04

- To be used on inserts Holder series WHITE and GREEN.
- This forming requires pre-pierce  $\varnothing 7,25 \pm 10\%$ .
- Multiple close formings might bend the sheet metal.
- Set of inserts composed of all elements showed on the side.

SET OF INSERTS M04			
POS.	DESCRIPTION	CODE	Q.ty
3	Screw	A0116805.019	2
4	Lower insert	FB09176942	1
5	Spring	A0903326.189	8
6	Stripper	FB09036942	1
7	Upper insert	FB09247242.844	1

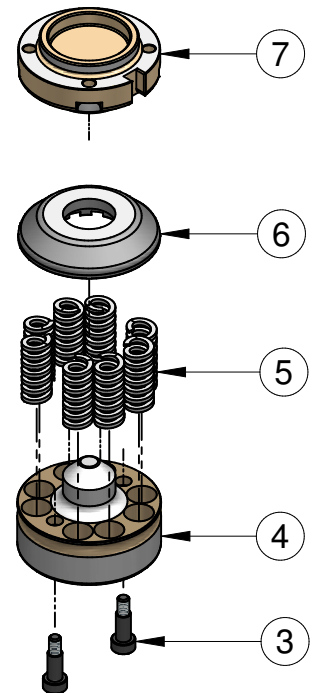

## UPPER INSERTS HOLDER

- Not included on the supply and not included on the price of the set of inserts.
- In case of order please specify one of the options indicated on the below table.

UPPER INSERTS HOLDER			
POS.	DESCRIPTION	CODE	✓
0	Not required	-	
1a	Adjustable round and shaped	FB08BA00	
1b	Adjustable round	FB09BA00	
1c	Fixed round and shaped	FB24BA00	
1d	Fixed round	FAZFBAA0	





Title	M04 10-1.0	Station :	B Thick Turret	Date :	20/12/2012	Telephone :	0039 0445 671015
	Round Countersink for M10 screw	Thickness :	0.80 ÷ 1.20	Rev :	0	Fax :	0039 0445 671035
Code :	FB09237243.305	Forming :	Up	Rev. Date :		E-Mail :	sales@matrixtools.eu

<http://www.matrixtools.eu/catalogues/deformations>

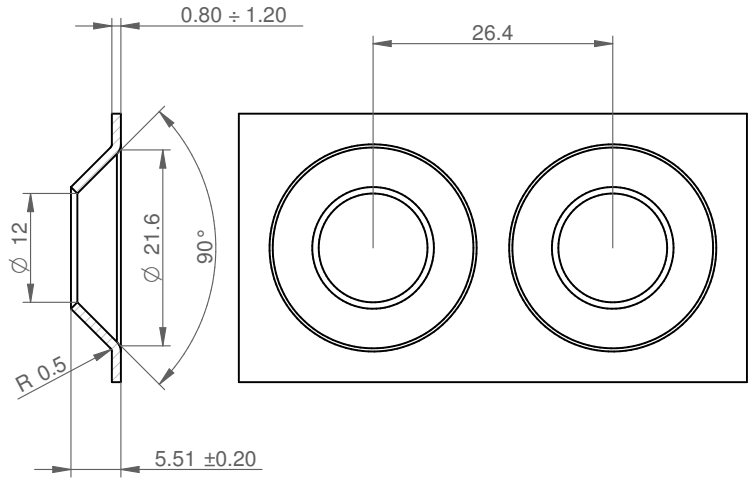
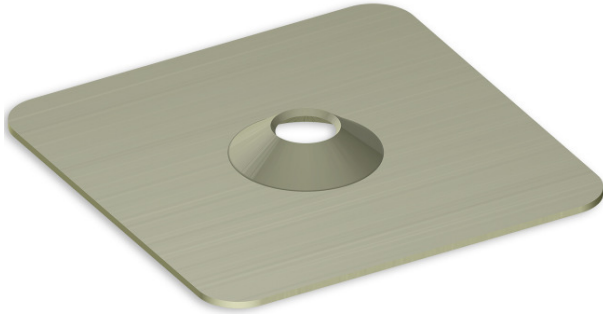

## SET OF INSERTS M04

- To be used on inserts Holder series WHITE and GREEN.
- This forming requires pre-pierce  $\varnothing 9,13 \pm 10\%$ .
- Multiple close formings might bend the sheet metal.
- Set of inserts composed of all elements showed on the side.

SET OF INSERTS M04			
POS.	DESCRIPTION	CODE	Q.ty
3	Screw	A0116805.019	2
4	Lower insert	FB09176943	1
5	Spring	A0903326.189	8
6	Stripper	FB09036943	1
7	Upper insert	FB09247243.305	1

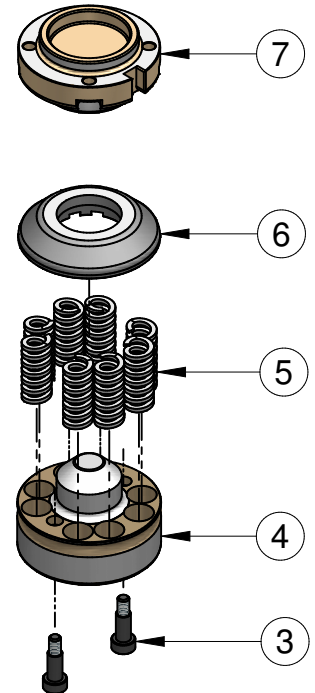

## UPPER INSERTS HOLDER

- Not included on the supply and not included on the price of the set of inserts.
- In case of order please specify one of the options indicated on the below table.

UPPER INSERTS HOLDER			
POS.	DESCRIPTION	CODE	✓
0	Not required	-	
1a	Adjustable round and shaped	FB08BA00	
1b	Adjustable round	FB09BA00	
1c	Fixed round and shaped	FB24BA00	
1d	Fixed round	FAZFBA00	







Title	M04 10-1.7	Station :	B Thick Turret	Date :	20/12/2012	Telephone :	0039 0445 671015
	Round Countersink for M10 screw	Thickness :	1.50 ÷ 1.90	Rev :	0	Fax :	0039 0445 671035
Code :	FB09237243.BP5	Forming :	Up	Rev. Date :		E-Mail :	sales@matrixtools.eu

<http://www.matrixtools.eu/catalogues/deformations>

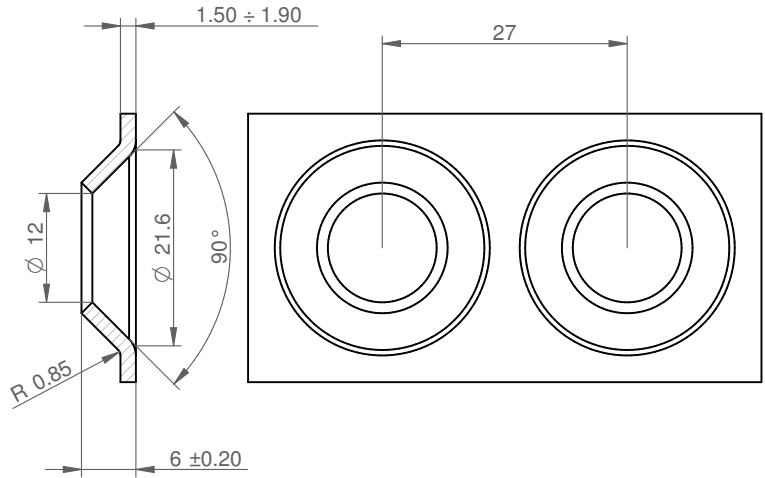
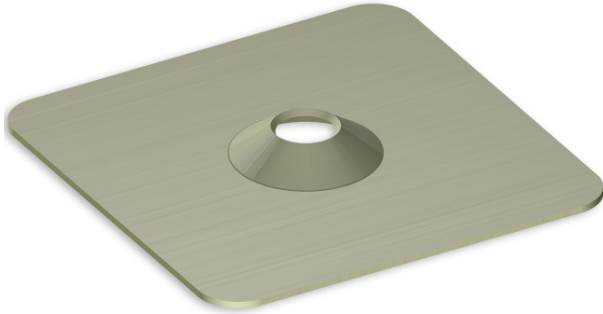

## SET OF INSERTS M04

- To be used on inserts Holder series WHITE and GREEN.
- This forming requires pre-pierce  $\varnothing 9,91 \pm 10\%$ .
- Multiple close formings might bend the sheet metal.
- Set of inserts composed of all elements showed on the side.

SET OF INSERTS M04			
POS.	DESCRIPTION	CODE	Q.ty
3	Screw	A0116805.019	2
4	Lower insert	FB09176943	1
5	Spring	A0903326.189	8
6	Stripper	FB09036943	1
7	Upper insert	FB09247243.BP5	1

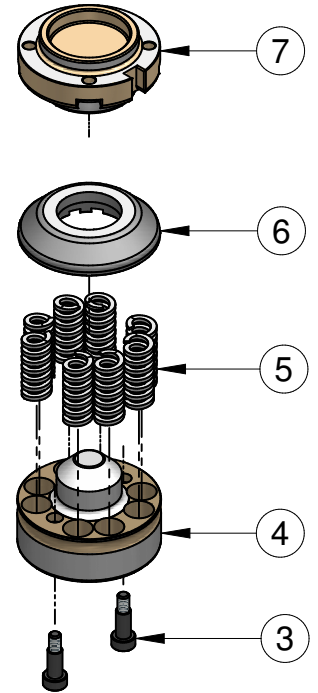

## UPPER INSERTS HOLDER

- Not included on the supply and not included on the price of the set of inserts.
- In case of order please specify one of the options indicated on the below table.

UPPER INSERTS HOLDER			
POS.	DESCRIPTION	CODE	✓
0	Not required	-	
1a	Adjustable round and shaped	FB08BA00	
1b	Adjustable round	FB09BA00	
1c	Fixed round and shaped	FB24BA00	
1d	Fixed round	FAZFBA00	





Title	M04 10-2.2	Station :	B Thick Turret	Date :	21/12/2012	Telephone :	0039 0445 671015
	Round Countersink for M10 screw	Thickness :	2.00 ÷ 2.50	Rev :	0	Fax :	0039 0445 671035
Code :	FB09237243.844	Forming :	Up	Rev. Date :		E-Mail :	sales@matrixtools.eu

<http://www.matrixtools.eu/catalogues/deformations>

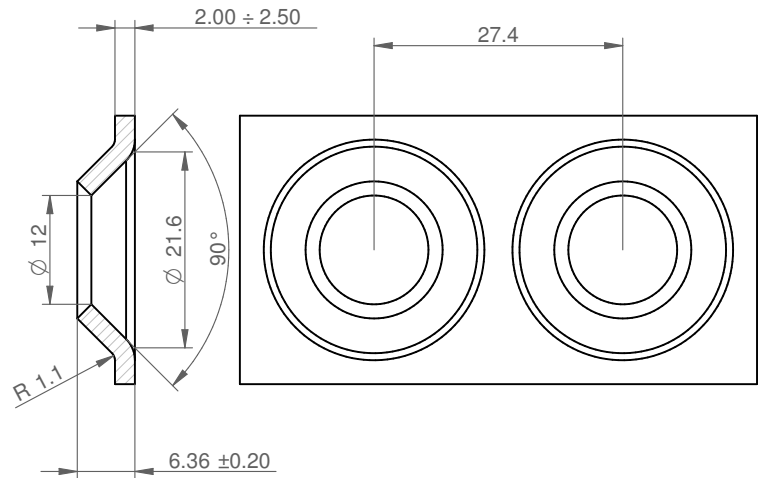

## SET OF INSERTS M04

- To be used on inserts Holder series WHITE and GREEN.
- This forming requires pre-pierce  $\varnothing 10,46 \pm 10\%$ .
- Multiple close formings might bend the sheet metal.
- Set of inserts composed of all elements showed on the side.

SET OF INSERTS M04			
POS.	DESCRIPTION	CODE	Q.ty
3	Screw	A0116805.019	2
4	Lower insert	FB09176943	1
5	Spring	A0903326.189	8
6	Stripper	FB09036943	1
7	Upper insert	FB09247243.844	1

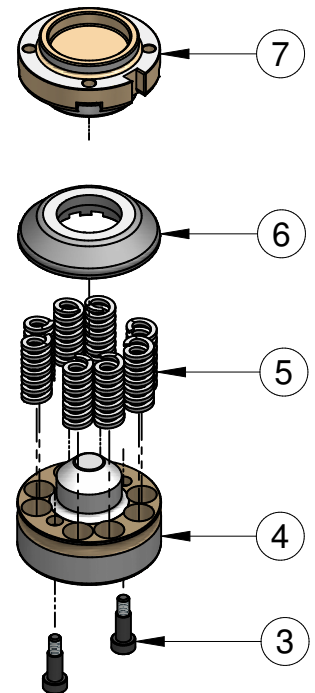

## UPPER INSERTS HOLDER

- Not included on the supply and not included on the price of the set of inserts.
- In case of order please specify one of the options indicated on the below table.

UPPER INSERTS HOLDER			
POS.	DESCRIPTION	CODE	✓
0	Not required	-	
1a	Adjustable round and shaped	FB08BA00	
1b	Adjustable round	FB09BA00	
1c	Fixed round and shaped	FB24BA00	
1d	Fixed round	FAZFBFA00	





Title <b>M09 00-1.0 Spring Clip</b>	Station : <b>B Thick Turret</b>	Date : 27/12/2012	Telephone : 0039 0445 671015
	Thickness : <b>0.80 ÷ 1.00</b>	Rev : 0	Fax : 0039 0445 671035
Code : <b>FB08237255.305</b>	Forming : Up	Rev. Date :	E-Mail : sales@matrixtools.eu

<http://www.matrixtools.eu/catalogues/deformations>

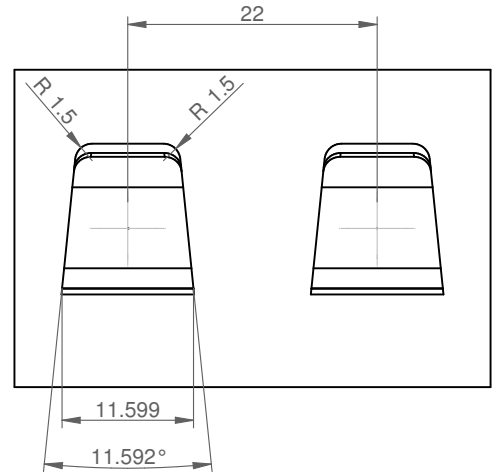
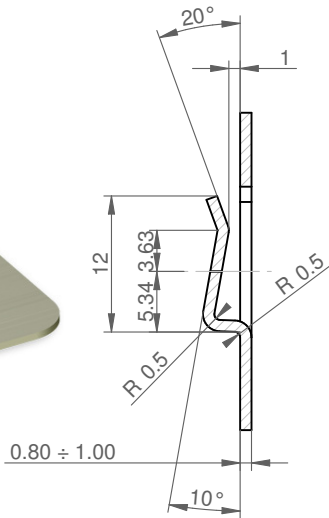
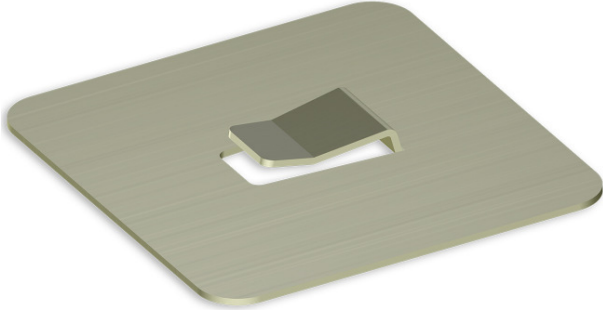

## SET OF INSERTS M09

- To be used on inserts Holder series WHITE and GREEN.
- Multiple close formings might bend the sheet metal.
- Set of inserts composed of all elements showed on the side.

SET OF INSERTS M09			
POS.	DESCRIPTION	CODE	Q.ty
3	Screw	A0116805.019	2
4	Lower insert	FB08176955.305	1
5	Stripper	FB08036955.305	1
6	Spring	A0903326.189	8
7	Upper insert	FB08247255.305	1
8	Eiextor	FB08557255.305	1
9	Spring	A0903325.221	1

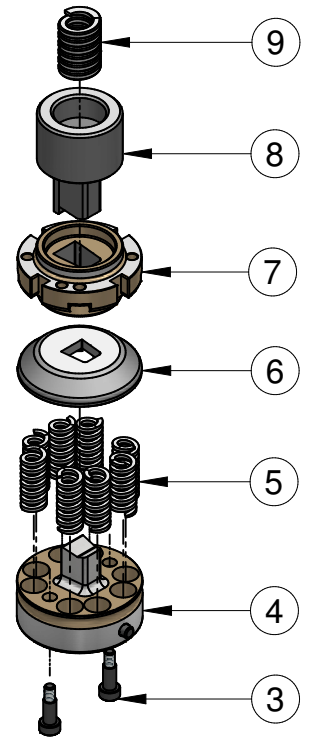

## UPPER INSERTS HOLDER

- Not included on the supply and not included on the price of the set of inserts.
- In case of order please specify one of the options indicated on the below table.

UPPER INSERTS HOLDER			
POS.	DESCRIPTION	CODE	✓
0	Not required	-	<input checked="" type="checkbox"/>
1a	Adjustable round and shaped	FB08BA00	<input type="checkbox"/>
1b	Fixed round and shaped	FB24BA00	<input type="checkbox"/>





Title <b>M09 00-1.2 Spring Clip</b>	Station : <b>B Thick Turret</b>	Date : 27/12/2012	Telephone : 0039 0445 671015
	Thickness : 1.10 ÷ 1.30	Rev : 0	Fax : 0039 0445 671035
Code : <b>FB08237255.979</b>	Forming : Up	Rev. Date :	E-Mail : sales@matrixtools.eu

<http://www.matrixtools.eu/catalogues/deformations>

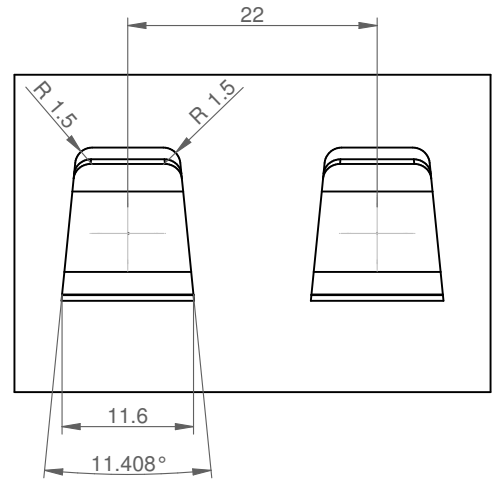
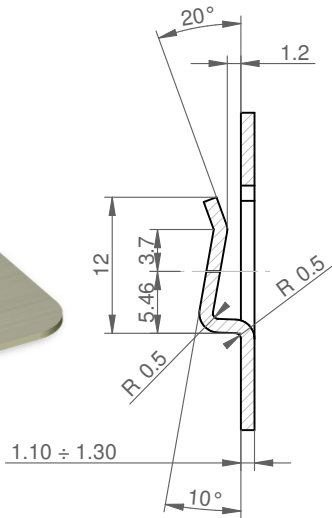
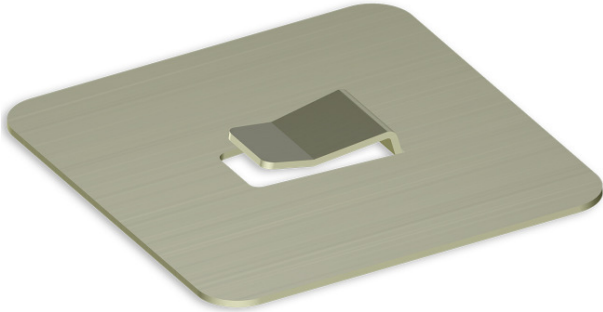

## SET OF INSERTS M09

- To be used on inserts Holder series WHITE and GREEN.
- Multiple close formings might bend the sheet metal.
- Set of inserts composed of all elements showed on the side.

SET OF INSERTS M09			
POS.	DESCRIPTION	CODE	Q.ty
3	Screw	A0116805.019	2
4	Lower insert	FB08176955.979	1
5	Stripper	FB08036955.979	1
6	Spring	A0903326.189	8
7	Upper insert	FB08247255.979	1
8	Eiextor	FB08557255.979	1
9	Spring	A0903325.221	1

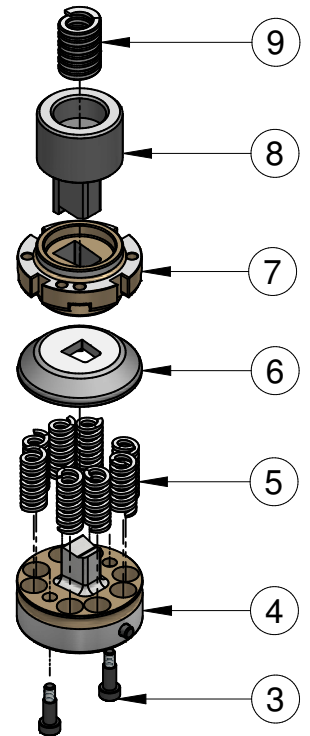

## UPPER INSERTS HOLDER

- Not included on the supply and not included on the price of the set of inserts.
- In case of order please specify one of the options indicated on the below table.

UPPER INSERTS HOLDER			
POS.	DESCRIPTION	CODE	✓
0	Not required	-	<input checked="" type="checkbox"/>
1a	Adjustable round and shaped	FB08BA00	<input type="checkbox"/>
1b	Fixed round and shaped	FB24BA00	<input type="checkbox"/>





Title	M09 00-1.5 Spring Clip	Station :	B Thick Turret	Date :	27/12/2012	Telephone :	0039 0445 671015
		Thickness :	1.40 ÷ 1.60	Rev :	0	Fax :	0039 0445 671035
Code :	FB08237255.A43	Forming :	Up	Rev. Date :		E-Mail :	sales@matrixtools.eu

<http://www.matrixtools.eu/catalogues/deformations>

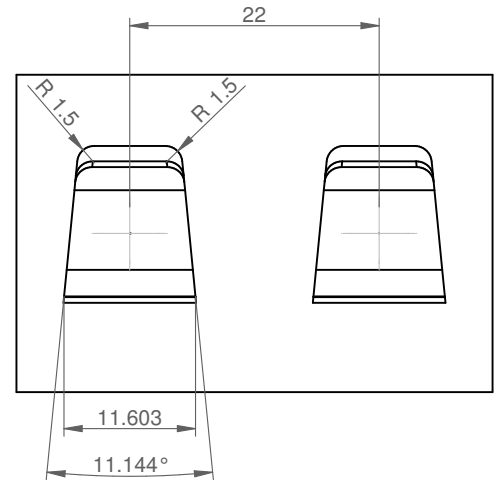
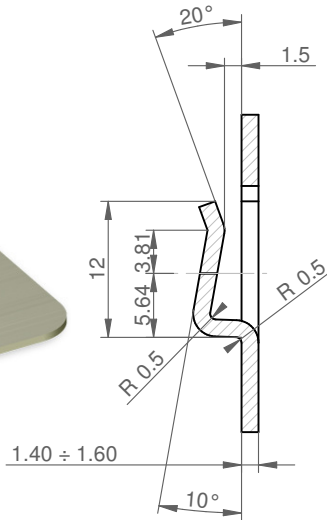
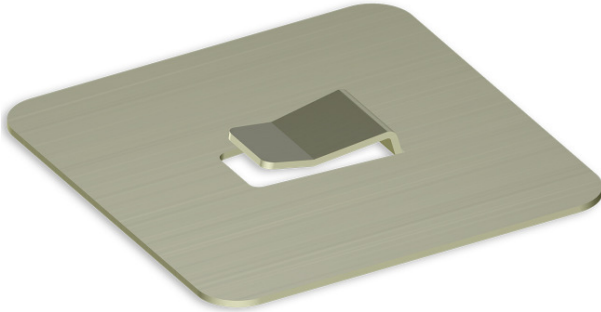

## SET OF INSERTS M09

- To be used on inserts Holder series WHITE and GREEN.
- Multiple close formings might bend the sheet metal.
- Set of inserts composed of all elements showed on the side.

SET OF INSERTS M09			
POS.	DESCRIPTION	CODE	Q.ty
3	Screw	A0116805.019	2
4	Lower insert	FB08176955.A43	1
5	Stripper	FB08036955.A43	1
6	Spring	A0903326.189	8
7	Upper insert	FB08247255.A43	1
8	Eiextor	FB08557255.A43	1
9	Spring	A0903325.221	1

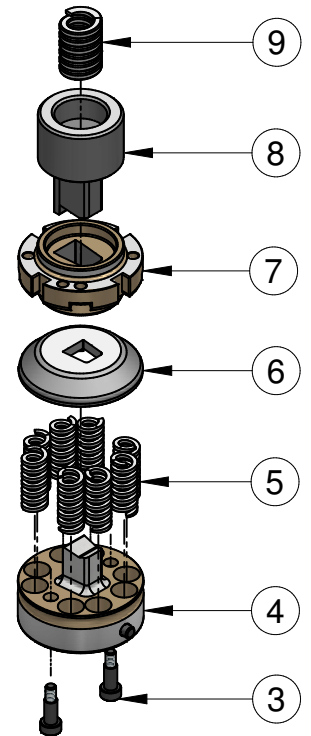

## UPPER INSERTS HOLDER

- Not included on the supply and not included on the price of the set of inserts.
- In case of order please specify one of the options indicated on the below table.

UPPER INSERTS HOLDER			
POS.	DESCRIPTION	CODE	✓
0	Not required	-	<input checked="" type="checkbox"/>
1a	Adjustable round and shaped	FB08BA00	<input type="checkbox"/>
1b	Fixed round and shaped	FB24BA00	<input type="checkbox"/>





Title	M12 00-2.0 Radius Back Louver	Station :	B Thick Turret	Date :	15/01/2013	Telephone :	0039 0445 671015
		Thickness :	0.80 ÷ 2.00	Rev :	0	Fax :	0039 0445 671035
Code :	FB08236968	Forming :	Up	Rev. Date :		E-Mail :	sales@matrixtools.eu

<http://www.matrixtools.eu/catalogues/deformations>

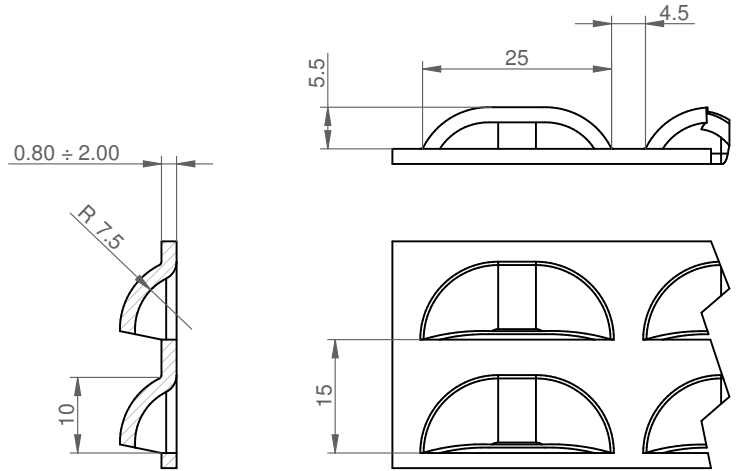
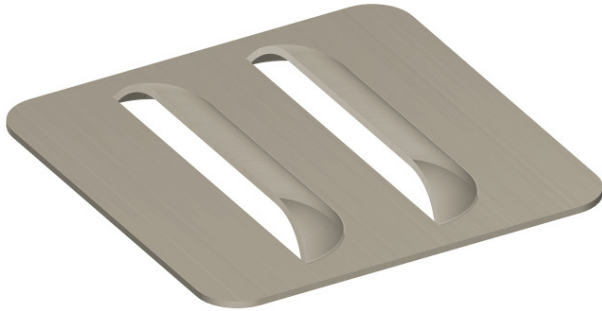

## SET OF INSERTS M15

- To be used on inserts Holder series WHITE and GREEN.
- Multiple close formings might bend the sheet metal.
- Set of inserts composed of all elements showed on the side.

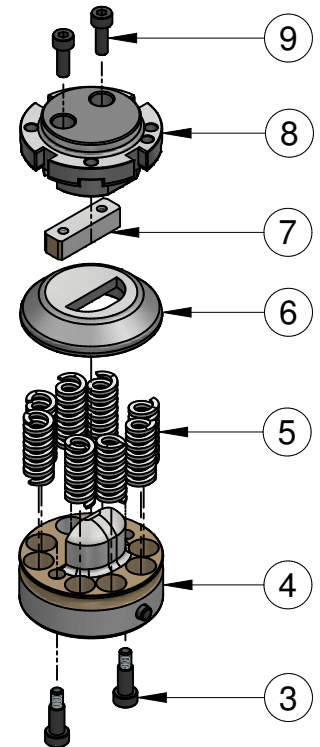

SET OF INSERTS M12			
POS.	DESCRIPTION	CODE	Q.ty
3	Screw	A0116805.019	2
4	Lower Insert	FB08406976	1
6	Stripper	FB08036968	1
7	Upper Shearing insert	FAJ3CP00	1
8	Upper Insert	FB08416968	1
9	Screw	A0100100.020	2
10	Spring	A0903326.189	8

## UPPER INSERTS HOLDER

- Not included on the supply and not included on the price of the set of inserts.
- In case of order please specify one of the options indicated on the below table.



UPPER INSERTS HOLDER			
POS.	DESCRIPTION	CODE	✓
0	Not required	-	
1a	Adjustable round and shaped	FB08BA00	
1b	Fixed round and shaped	FB24BA00	





Title	M12 00-2.0 Radius Back Louver	Station :	C Thick Turret	Date :	15/01/2013	Telephone :	0039 0445 671015
		Thickness :	0.80 ÷ 2.00	Rev :	0	Fax :	0039 0445 671035
Code :	FB10236968	Forming :	Up	Rev. Date :		E-Mail :	sales@matrixtools.eu

<http://www.matrixtools.eu/catalogues/deformations>

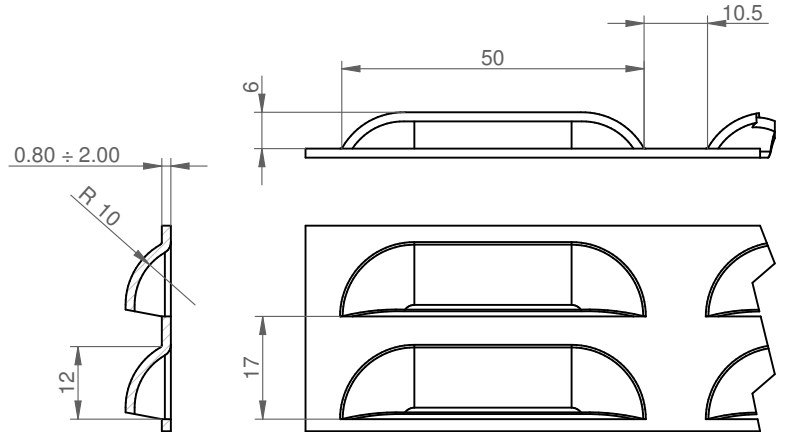
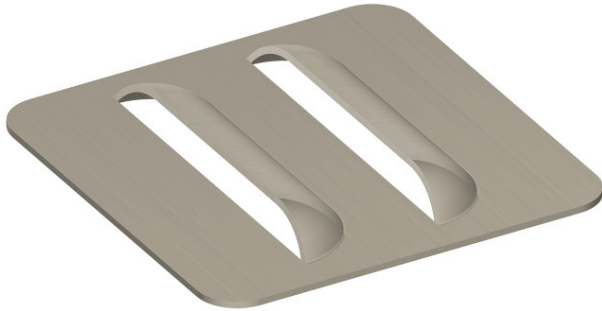

## SET OF INSERTS M12

- To be used on inserts Holder series WHITE and GREEN.
- Multiple close formings might bend the sheet metal.
- Set of inserts composed of all elements showed on the side.

SET OF INSERTS M12			
POS.	DESCRIPTION	CODE	Q.ty
3	Lower Insert	FB10406968	1
4	Spring	A0903326.217	8
5	Stripper	FB10036968	1
6	Upper Shearing insert	F504CP00	1
7	Upper Insert	FB10416968	1
8	Screw	A0100100.034	2

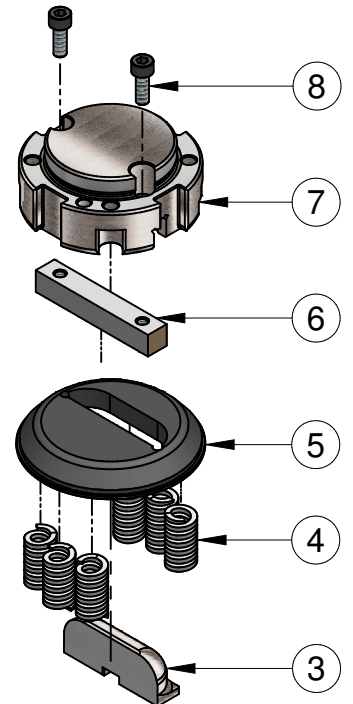

## UPPER INSERTS HOLDER

- Not included on the supply and not included on the price of the set of inserts.
- In case of order please specify one of the options indicated on the below table.

UPPER INSERTS HOLDER			
POS.	DESCRIPTION	CODE	✓
0	Not required	-	<input checked="" type="checkbox"/>
1a	Adjustable round and shaped	FB10BA00	<input type="checkbox"/>
1b	Fixed round and shaped	FAQ9BA00	<input type="checkbox"/>

LOWER INSERTS HOLDER			
POS.	DESCRIPTION	CODE	✓
0	Not required	-	<input checked="" type="checkbox"/>
2	Lower Insert Holder	FB10BY00	<input type="checkbox"/>

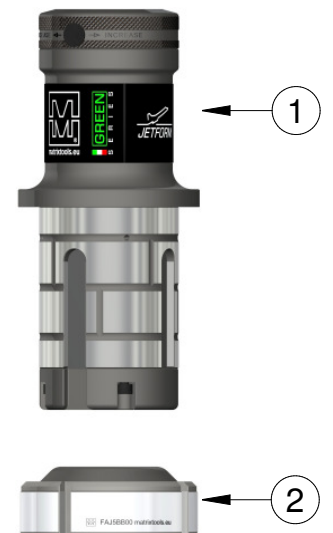



Title	M12 00-2.0 Radius Back Louver	Station :	D Thick Turret	Date :	15/01/2013	Telephone :	0039 0445 671015
		Thickness :	0.80 ÷ 2.00	Rev :	0	Fax :	0039 0445 671035
Code :	FB12236968	Forming :	Up	Rev. Date :		E-Mail :	sales@matrixtools.eu

<http://www.matrixtools.eu/catalogues/deformations>

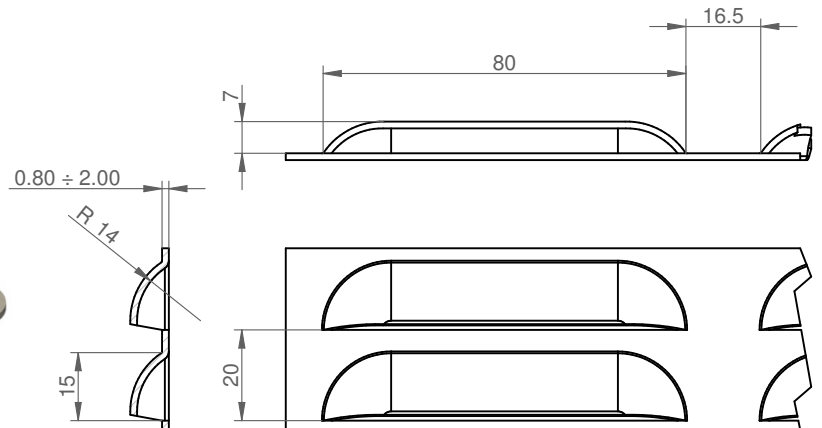
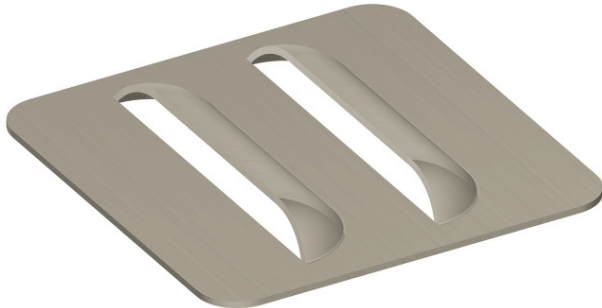

## SET OF INSERTS M12

- To be used on inserts Holder series WHITE and GREEN.
- Multiple close formings might bend the sheet metal.
- Set of inserts composed of all elements showed on the side.

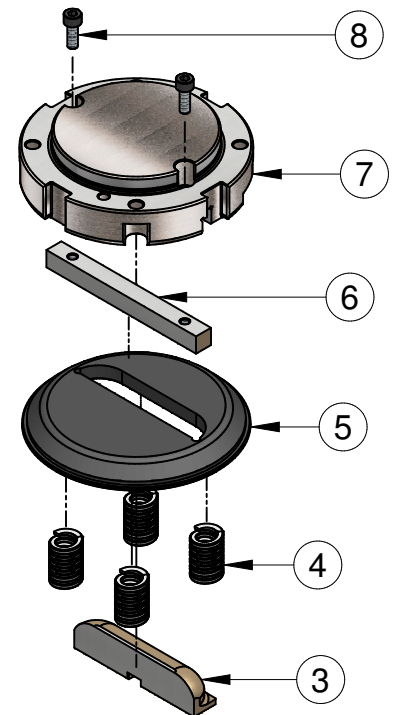

SET OF INSERTS M12			
POS.	DESCRIPTION	CODE	Q.ty
3	Lower Insert	FB12406968	1
4	Spring	A0903326.221	4
5	Stripper	FB12036968	1
6	Upper Shearing insert	F505CP00	1
7	Upper Insert	FB12416968	1
8	Screw	A0100100.034	2

## UPPER INSERTS HOLDER

- Not included on the supply and not included on the price of the set of inserts.
- In case of order please specify one of the options indicated on the below table.

UPPER INSERTS HOLDER			
POS.	DESCRIPTION	CODE	✓
0	Not required	-	<input checked="" type="checkbox"/>
1a	Adjustable round and shaped	FB12BA00	<input type="checkbox"/>
1b	Fixed round and shaped	FAR0BA00	<input type="checkbox"/>

LOWER INSERTS HOLDER			
POS.	DESCRIPTION	CODE	✓
0	Not required	-	<input checked="" type="checkbox"/>
2	Lower Insert Holder	FB12BY00	<input type="checkbox"/>

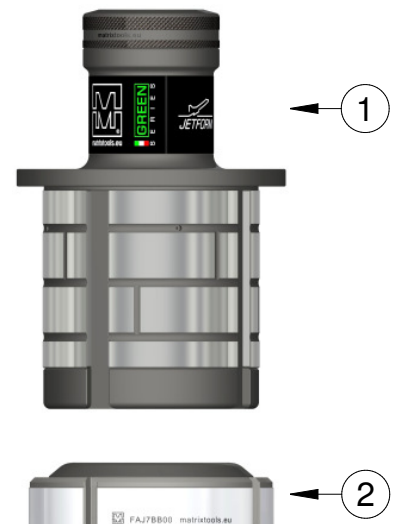



Title	M13 05-4.0 Shear Button $\varnothing 5$	Station :	B Thick Turret	Date :	03/12/2012	Telephone :	0039 0445 671015
		Thickness :	1.00 $\div$ 4.00	Rev :	0	Fax :	0039 0445 671035
Code :	FB09237471	Forming :	Up	Rev. Date :		E-Mail :	sales@matrixtools.eu

<http://www.matrixtools.eu/catalogues/deformations>

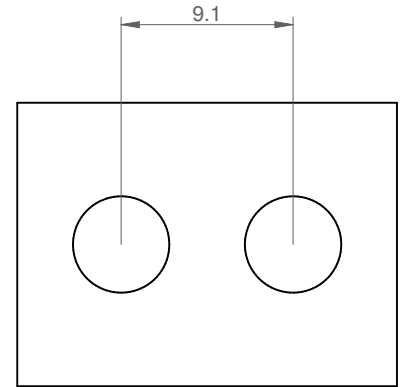
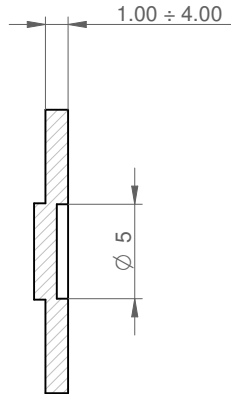
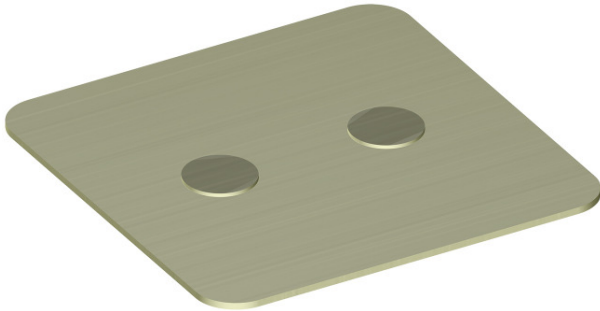

## SET OF INSERTS M13

- To be used on inserts Holder series WHITE and GREEN.
- Multiple close formings might bend the sheet metal.
- Set of inserts composed of all elements showed on the side.

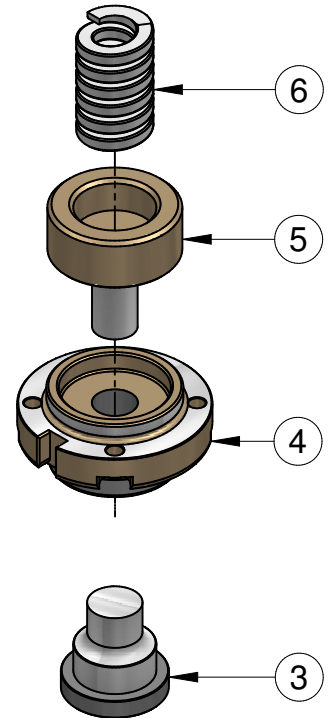

SET OF INSERTS M13			
POS.	DESCRIPTION	CODE	Q.ty
3	Lower Insert	FB09667171	1
4	Upper Insert	FB09247271	1
5	Ejector	FB09550071	1
6	Spring	A0903325.222	1

## UPPER INSERTS HOLDER

- Not included on the supply and not included on the price of the set of inserts.
- In case of order please specify one of the options indicated on the below table.

UPPER INSERTS HOLDER			
POS.	DESCRIPTION	CODE	✓
0	Not required	-	
1a	Adjustable round and shaped	FB08BA00	
1b	Adjustable round	FB09BA00	
1c	Fixed round and shaped	FB24BA00	
1d	Fixed round	FAZFBA00	

LOWER INSERTS HOLDER			
POS.	DESCRIPTION	CODE	✓
0	Not required	-	
2	Inserts Holder up to $\varnothing 10$	FAJ4BB00	





Title	M13 08-4.0 Shear Button $\varnothing 8$	Station :	B Thick Turret	Date :	03/12/2012	Telephone :	0039 0445 671015
		Thickness :	1.00 $\div$ 4.00	Rev :	0	Fax :	0039 0445 671035
Code :	FB09237470	Forming :	Up	Rev. Date :		E-Mail :	sales@matrixtools.eu

<http://www.matrixtools.eu/catalogues/deformations>

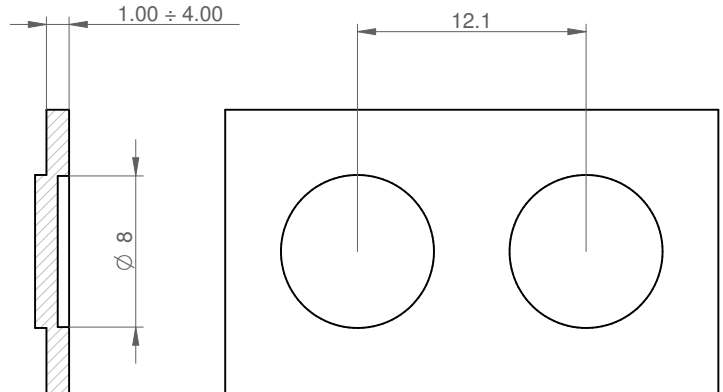
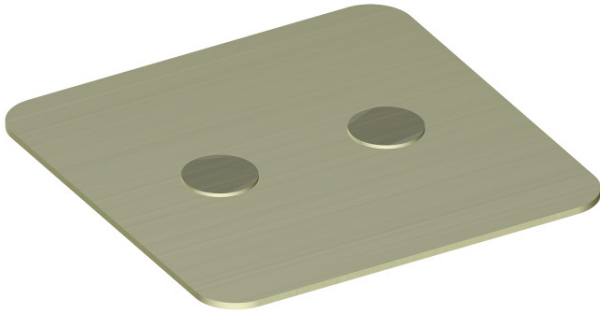

## SET OF INSERTS M13

- To be used on inserts Holder series WHITE and GREEN.
- Multiple close formings might bend the sheet metal.
- Set of inserts composed of all elements showed on the side.

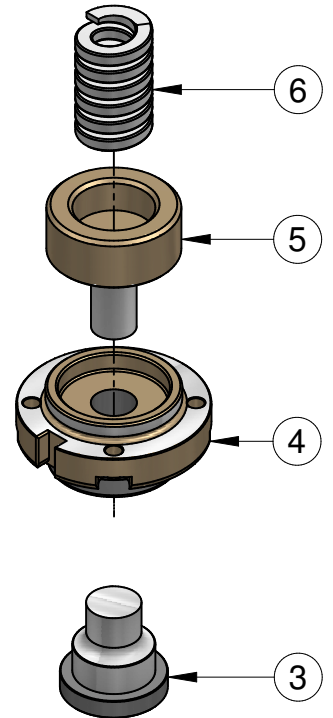

SET OF INSERTS M13			
POS.	DESCRIPTION	CODE	Q.ty
3	Lower Insert	FB09667170	1
4	Upper Insert	FB09247270	1
5	Ejector	FB09550070	1
6	Spring	A0903325.222	1

## UPPER INSERTS HOLDER

- Not included on the supply and not included on the price of the set of inserts.
- In case of order please specify one of the options indicated on the below table.

UPPER INSERTS HOLDER			
POS.	DESCRIPTION	CODE	✓
0	Not required	-	
1a	Adjustable round and shaped	FB08BA00	
1b	Adjustable round	FB09BA00	
1c	Fixed round and shaped	FB24BA00	
1d	Fixed round	FAZFBA00	

LOWER INSERTS HOLDER			
POS.	DESCRIPTION	CODE	✓
0	Not required	-	
2	Inserts Holder up to $\varnothing 10$	FAJ4BB00	





Title	M14 00-4.0	Station :	B Thick Turret	Date :	07/01/2013	Telephone :	0039 0445 671015
	Ground Symbol With Circle	Thickness :	0.50±4.00	Rev :	0	Fax :	0039 0445 671035
Code :	FB08237273	Forming :	Up	Rev. Date :		E-Mail :	sales@matrixtools.eu

Station :	B Thick Turret	Date :	07/01/2013	Telephone :	0039 0445 671015
Thickness :	0.50±4.00	Rev :	0	Fax :	0039 0445 671035
Forming :	Up	Rev. Date :		E-Mail :	sales@matrixtools.eu

<http://www.matrixtools.eu/catalogues/deformations>

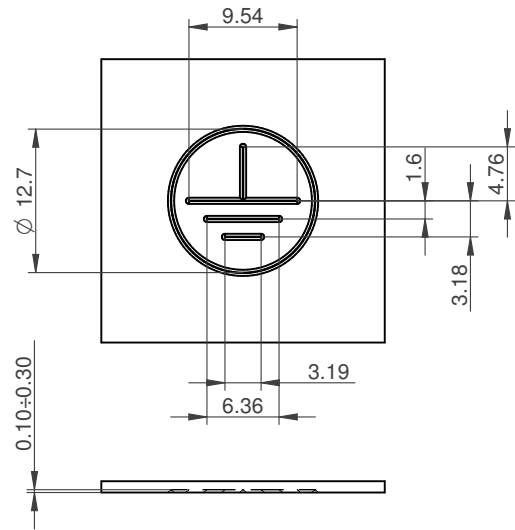

## SET OF INSERTS M14

- To be used on inserts Holder series WHITE and GREEN.
- Multiple close formings might bend the sheet metal.
- Set of inserts composed of all elements showed on the side.

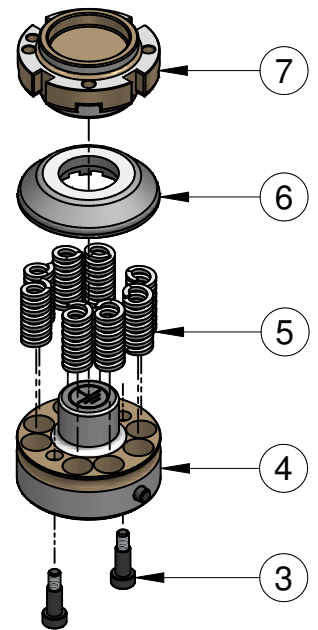

SET OF INSERTS M14			
POS.	DESCRIPTION	CODE	Q.ty
3	Screw	A0116805.019	2
4	Lower Insert	FB08176973	1
5	Spring	A0903326.189	8
6	Stripper	FB08036973	1
7	Upper Insert	FB08247273	1

## UPPER INSERTS HOLDER

- Not included on the supply and not included on the price of the set of inserts.
- In case of order please specify one of the options indicated on the below table.



UPPER INSERTS HOLDER			
POS.	DESCRIPTION	CODE	✓
0	Not required	-	✓
1a	Adjustable round and shaped	FB08BA00	
1b	Fixed round and shaped	FB24BA00	



Title	M14 01-4.0 Ground Symbol Without Circle	Station :	B Thick Turret	Date :	07/01/2013	Telephone :	0039 0445 671015
		Thickness :	0.50±4.00	Rev :	0	Fax :	0039 0445 671035
Code :	FB08237274	Forming :	Up	Rev. Date :		E-Mail :	sales@matrixtools.eu

<http://www.matrixtools.eu/catalogues/deformations>

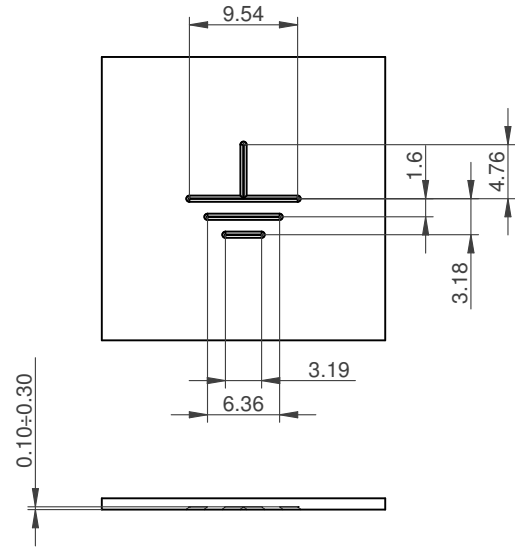
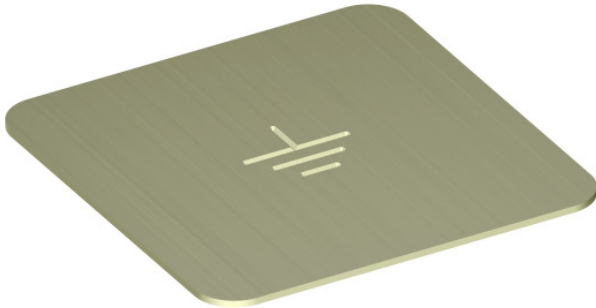

## SET OF INSERTS M14

- To be used on inserts Holder series WHITE and GREEN.
- Multiple close formings might bend the sheet metal.
- Set of inserts composed of all elements showed on the side.

SET OF INSERTS M14			
POS.	DESCRIPTION	CODE	Q.ty
3	Screw	A0116805.019	2
4	Lower Insert	FB08176974	1
5	Spring	A0903326.189	8
6	Stripper	FB08036974	1
7	Upper Insert	FB08247274	1

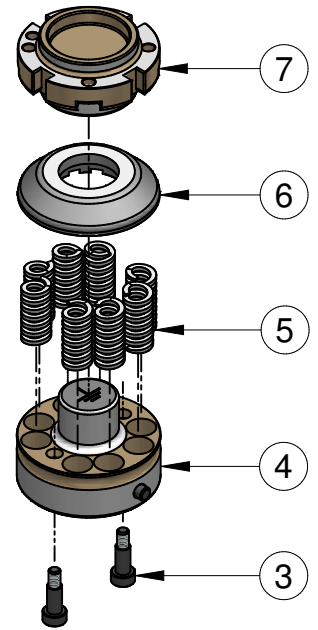

## UPPER INSERTS HOLDER

- Not included on the supply and not included on the price of the set of inserts.
- In case of order please specify one of the options indicated on the below table.

UPPER INSERTS HOLDER			
POS.	DESCRIPTION	CODE	✓
0	Not required	-	
1a	Adjustable round and shaped	FB08BA00	
1b	Fixed round and shaped	FB24BA00	







Title	M14 00-4.0 Ground Symbol With Circle	Station :	B Thick Turret	Date :	07/01/2013	Telephone :	0039 0445 671015
		Thickness :	0.50±4.00	Rev :	0	Fax :	0039 0445 671035
Code :	FB08238173	Forming :	Down	Rev. Date :		E-Mail :	sales@matrixtools.eu

<http://www.matrixtools.eu/catalogues/deformations>

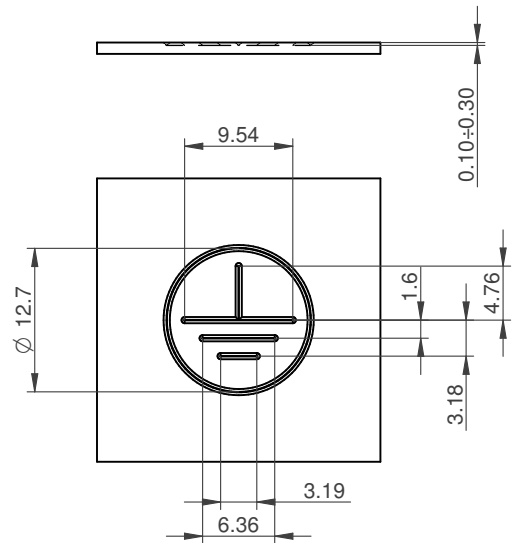

## SET OF INSERTS M14

- To be used on inserts Holder series WHITE and GREEN.
- Multiple close formings might bend the sheet metal.
- Set of inserts composed of all elements showed on the side.

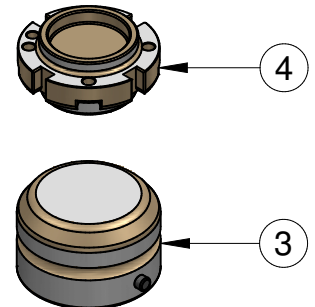

SET OF INSERTS M14			
POS.	DESCRIPTION	CODE	Q.ty
3	Solid Die	F222X000	1
4	Upper Insert	FB08248473	1

## UPPER INSERTS HOLDER

- Not included on the supply and not included on the price of the set of inserts.
- In case of order please specify one of the options indicated on the below table.



UPPER INSERTS HOLDER			
POS.	DESCRIPTION	CODE	✓
0	Not required	-	<input checked="" type="checkbox"/>
1a	Adjustable round and shaped	FB08BA00	<input type="checkbox"/>
1b	Fixed round and shaped	FB24BA00	<input type="checkbox"/>



Title	M14 01-4.0 Ground Symbol Without Circle	Station :	B Thick Turret	Date :	07/01/2013	Telephone :	0039 0445 671015
		Thickness :	0.50±4.00	Rev :	0	Fax :	0039 0445 671035
Code :	FB08238174	Forming :	Down	Rev. Date :		E-Mail :	sales@matrixtools.eu

<http://www.matrixtools.eu/catalogues/deformations>

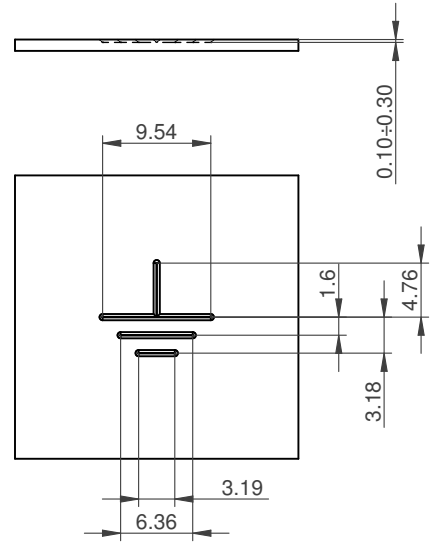

## SET OF INSERTS M14

- To be used on inserts Holder series WHITE and GREEN.
- Multiple close formings might bend the sheet metal.
- Set of inserts composed of all elements showed on the side.

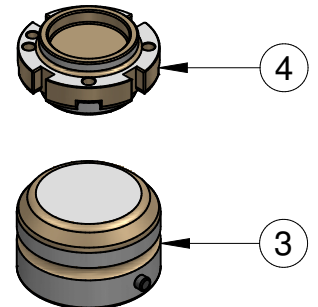

SET OF INSERTS M14			
POS.	DESCRIPTION	CODE	Q.ty
3	Solid Die	F222X000	1
4	Upper Insert	FB08248474	1

## UPPER INSERTS HOLDER

- Not included on the supply and not included on the price of the set of inserts.
- In case of order please specify one of the options indicated on the below table.



UPPER INSERTS HOLDER			
POS.	DESCRIPTION	CODE	✓
0	Not required	-	✓
1a	Adjustable round and shaped	FB08BA00	
1b	Fixed round and shaped	FB24BA00	



Title	M15 00-1.0 Continuous Radius Back Louver	Station :	B Thick Turret	Date :	28/12/2012	Telephone :	0039 0445 671015
		Thickness :	0.80 ±1.20	Rev :	0	Fax :	0039 0445 671035
Code :	FB08237476.305	Forming :	Up	Rev. Date :		E-Mail :	sales@matrixtools.eu

<http://www.matrixtools.eu/catalogues/deformations>

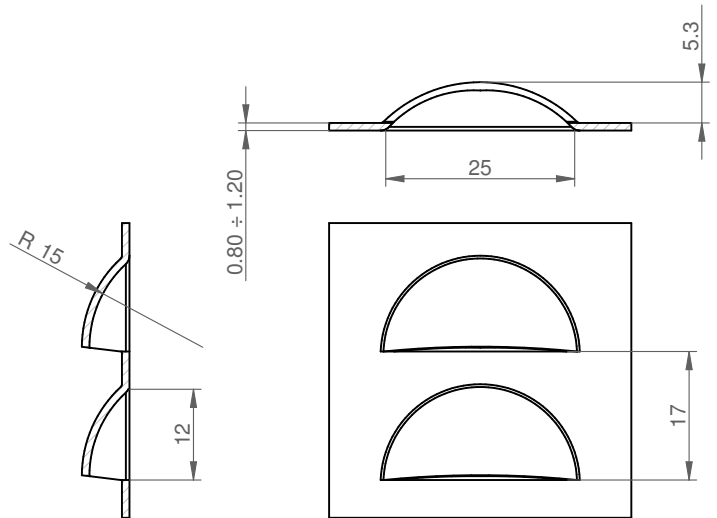
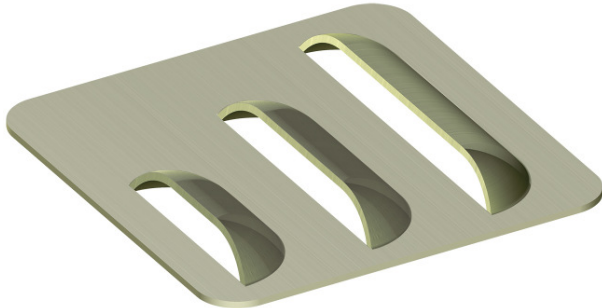

## SET OF INSERTS M15

- To be used on inserts Holder series WHITE and GREEN.
- Multiple close formings might bend the sheet metal.
- Set of inserts composed of all elements showed on the side.

SET OF INSERTS M15			
POS.	DESCRIPTION	CODE	Q.ty
1	Stripper	FB08036976	1
3	Screw	A0116805.019	2
4	Lower insert	FB08177176	1
5	Spring	A0903326.189	8
7	Upper Shearing insert	FAJ3CP00	1
8	Upper insert	FB08247276.305	1
9	Screw	A0100100.020	2

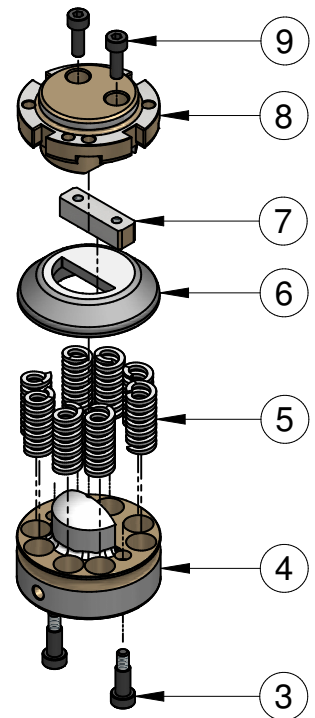

## UPPER INSERTS HOLDER

- Not included on the supply and not included on the price of the set of inserts.
- In case of order please specify one of the options indicated on the below table.

UPPER INSERTS HOLDER			
POS.	DESCRIPTION	CODE	✓
0	Not required	-	<input checked="" type="checkbox"/>
1a	Adjustable round and shaped	FB08BA00	<input type="checkbox"/>
1b	Fixed round and shaped	FB24BA00	<input type="checkbox"/>





Title	M15 00-1.5 Continuous Radius Back Louver	Station :	B Thick Turret	Date :	28/12/2012	Telephone :	0039 0445 671015
		Thickness :	1.30 ±1.70	Rev :	0	Fax :	0039 0445 671035
Code :	FB08237476.A43	Forming :	Up	Rev. Date :		E-Mail :	sales@matrixtools.eu

<http://www.matrixtools.eu/catalogues/deformations>

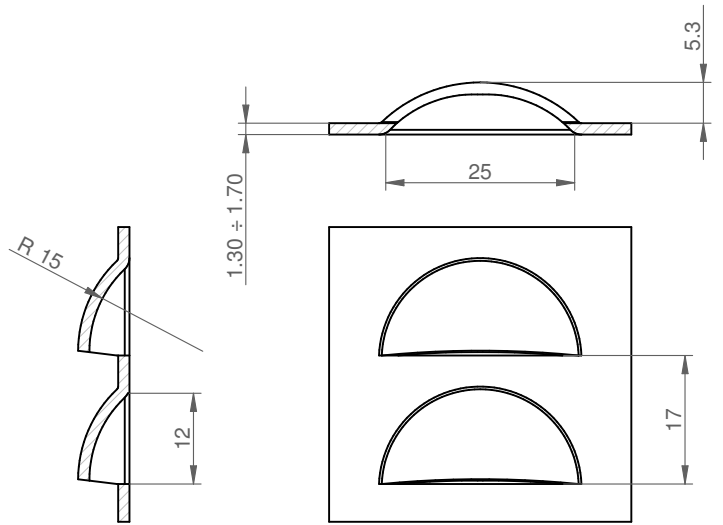
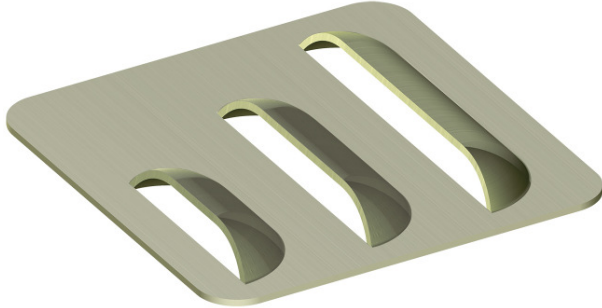

## SET OF INSERTS M15

- To be used on inserts Holder series WHITE and GREEN.
- Multiple close formings might bend the sheet metal.
- Set of inserts composed of all elements showed on the side.

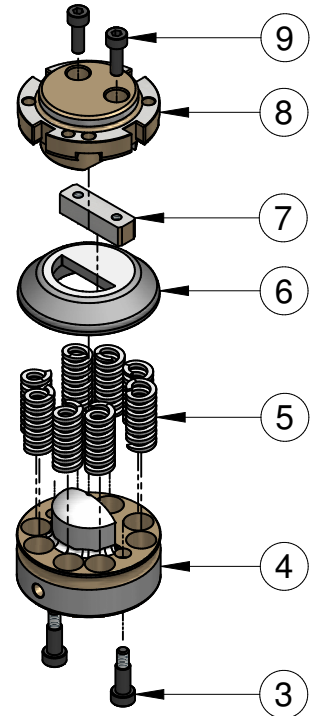

SET OF INSERTS M15			
POS.	DESCRIPTION	CODE	Q.ty
1	Stripper	FB08036976	1
3	Screw	A0116805.019	2
4	Lower insert	FB08177176	1
5	Spring	A0903326.189	8
7	Upper Shearing insert	FAJ3CP00	1
8	Upper insert	FB08247276.A43	1
9	Screw	A0100100.020	2

## UPPER INSERTS HOLDER

- Not included on the supply and not included on the price of the set of inserts.
- In case of order please specify one of the options indicated on the below table.



UPPER INSERTS HOLDER			
POS.	DESCRIPTION	CODE	✓
0	Not required	-	<input checked="" type="checkbox"/>
1a	Adjustable round and shaped	FB08BA00	<input type="checkbox"/>
1b	Fixed round and shaped	FB24BA00	<input type="checkbox"/>



Title	M15 00-2.2 Continuous Radius Back Louver	Station :	B Thick Turret	Date :	28/12/2012	Telephone :	0039 0445 671015
		Thickness :	1.80 ±2.50	Rev :	0	Fax :	0039 0445 671035
Code :	FB08237476.844	Forming :	Up	Rev. Date :		E-Mail :	sales@matrixtools.eu

<http://www.matrixtools.eu/catalogues/deformations>

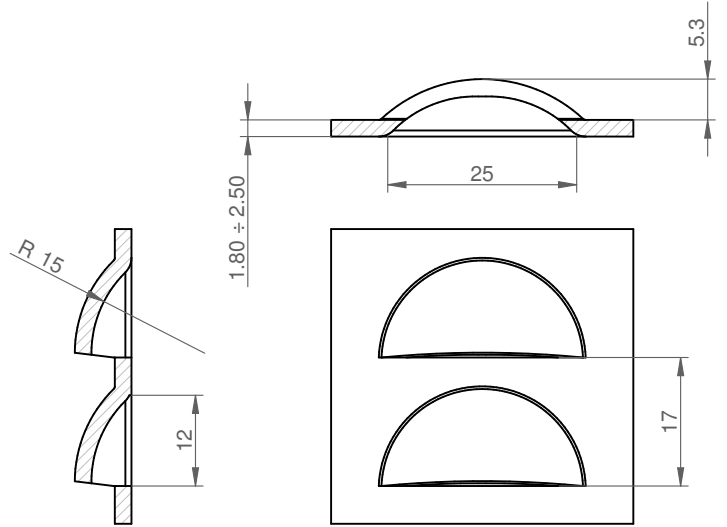
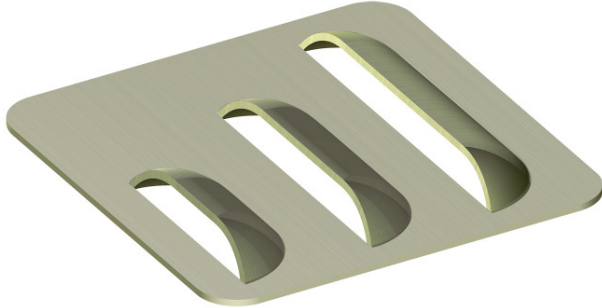

## SET OF INSERTS M15

- To be used on inserts Holder series WHITE and GREEN.
- Multiple close formings might bend the sheet metal.
- Set of inserts composed of all elements showed on the side.

SET OF INSERTS M15			
POS.	DESCRIPTION	CODE	Q.ty
1	Stripper	FB08036976	1
3	Screw	A0116805.019	2
4	Lower insert	FB08177176	1
5	Spring	A0903326.189	8
7	Upper Shearing insert	FAJ3CP00	1
8	Upper insert	FB08247276.844	1
9	Screw	A0100100.020	2

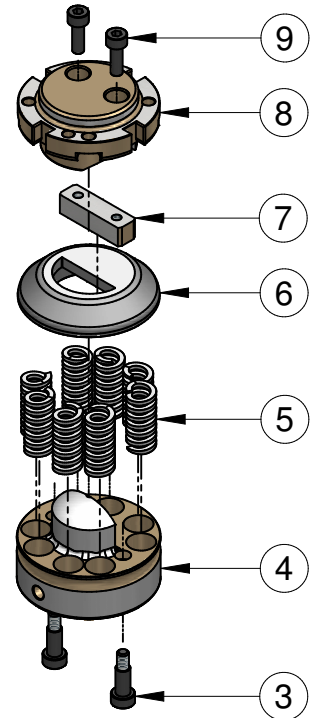

## UPPER INSERTS HOLDER

- Not included on the supply and not included on the price of the set of inserts.
- In case of order please specify one of the options indicated on the below table.

UPPER INSERTS HOLDER			
POS.	DESCRIPTION	CODE	✓
0	Not required	-	<input checked="" type="checkbox"/>
1a	Adjustable round and shaped	FB08BA00	<input type="checkbox"/>
1b	Fixed round and shaped	FB24BA00	<input type="checkbox"/>





Title	M15 00-1.0 Continuous Radius Back Louver	Station :	C Thick Turret	Date :	08/01/2013	Telephone :	0039 0445 671015
		Thickness :	0.80 ÷ 1.20	Rev :	0	Fax :	0039 0445 671035
Code :	FB10237476.305	Forming :	Up	Rev. Date :		E-Mail :	sales@matrixtools.eu

<http://www.matrixtools.eu/catalogues/deformations>

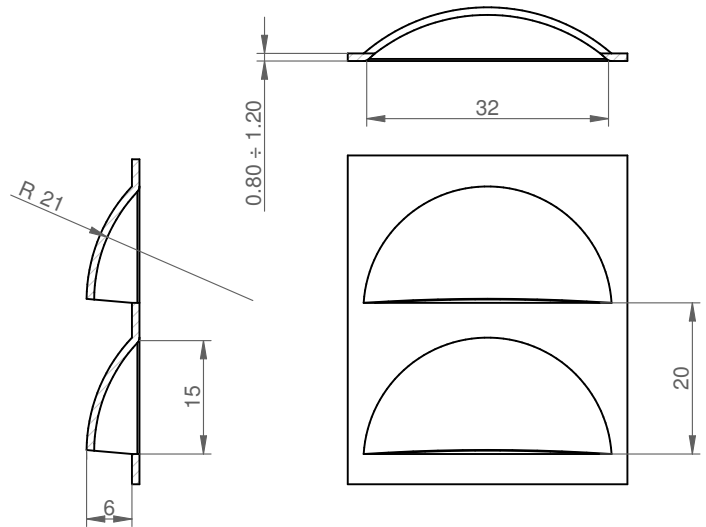
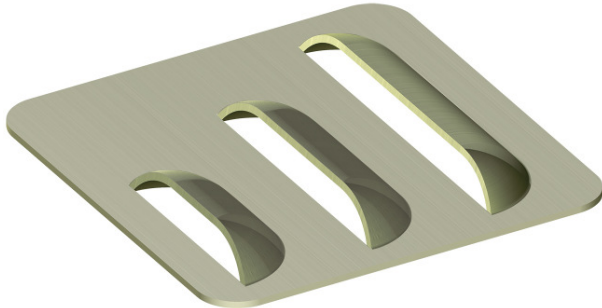

## SET OF INSERTS M15

- To be used on inserts Holder series WHITE and GREEN.
- Multiple close formings might bend the sheet metal.
- Set of inserts composed of all elements showed on the side.

SET OF INSERTS M15			
POS.	DESCRIPTION	CODE	Q.ty
3	Lower Insert	FB10177176	1
4	Spring	A0903326.217	12
5	Upper Shearing insert	FB10CP00	1
6	Stipper	FB10036976	1
7	Upper insert	FB10247276.305	1
8	Screw	A0100100.022	2

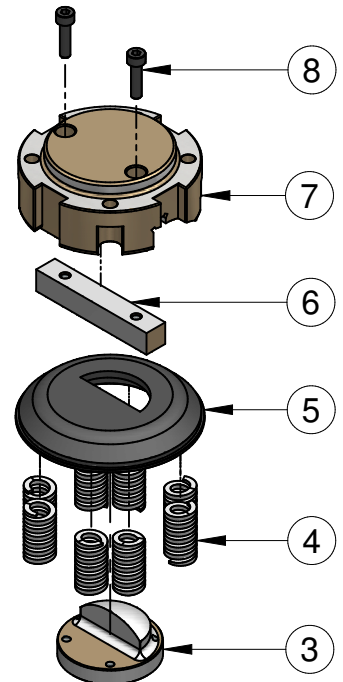

## UPPER INSERTS HOLDER

- Not included on the supply and not included on the price of the set of inserts.
- In case of order please specify one of the options indicated on the below table.

UPPER INSERTS HOLDER			
POS.	DESCRIPTION	CODE	✓
0	Not required	-	<input checked="" type="checkbox"/>
1a	Adjustable round and shaped	FB10BA00	<input type="checkbox"/>
1b	Fixed round and shaped	FAQ9BA00	<input type="checkbox"/>

LOWER INSERTS HOLDER			
POS.	DESCRIPTION	CODE	✓
0	Not required	-	<input checked="" type="checkbox"/>
2	Lower Insert Holder	FB10BB00	<input type="checkbox"/>

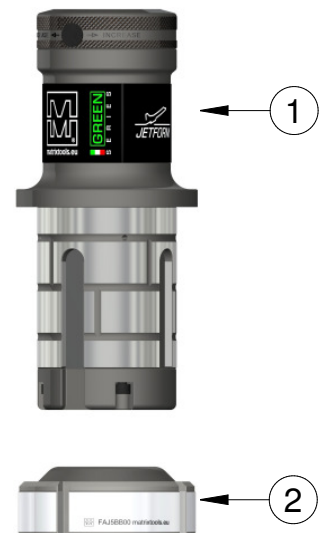





Title	M15 00-1.5	Station :	C Thick Turret	Date :	08/01/2013	Telephone :	0039 0445 671015
	Continuous Radius Back Louver	Thickness :	1.30 ÷ 1.70	Rev :	0	Fax :	0039 0445 671035
Code :	FB10237476.A43	Forming :	Up	Rev. Date :		E-Mail :	sales@matrixtools.eu

<http://www.matrixtools.eu/catalogues/deformations>

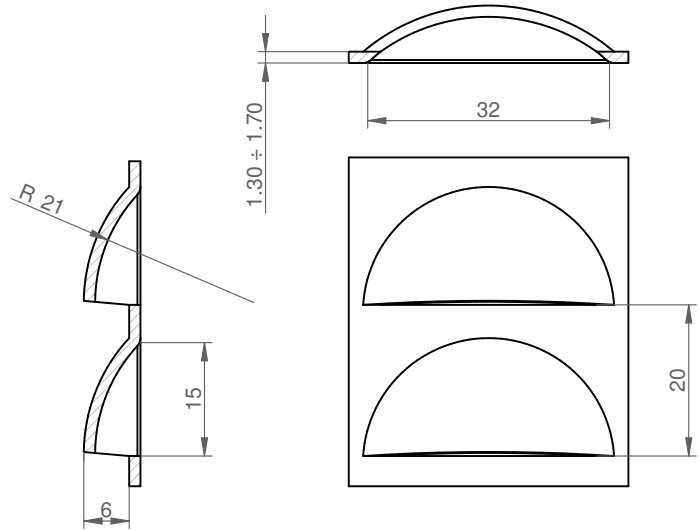
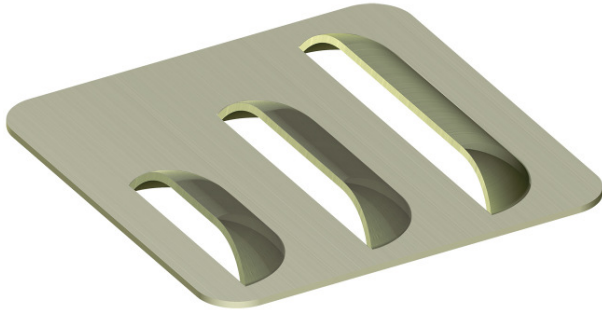

## SET OF INSERTS M15

- To be used on inserts Holder series WHITE and GREEN.
- Multiple close formings might bend the sheet metal.
- Set of inserts composed of all elements showed on the side.

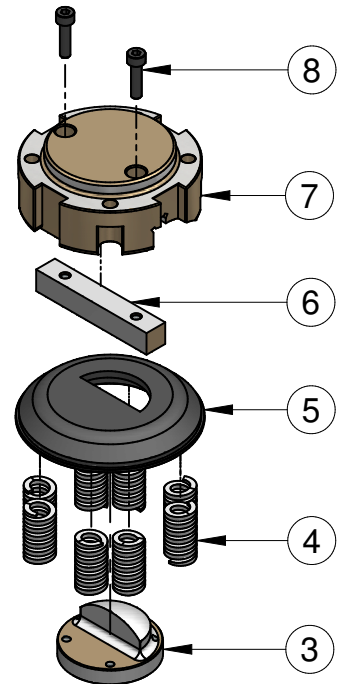

SET OF INSERTS M15			
POS.	DESCRIPTION	CODE	Q.ty
3	Lower Insert	FB10177176	1
4	Spring	A0903326.217	12
5	Upper Shearing insert	FB10CP00	1
6	Stipper	FB10036976	1
7	Upper insert	FB10247276.A43	1
8	Screw	A0100100.022	2

## UPPER INSERTS HOLDER

- Not included on the supply and not included on the price of the set of inserts.
- In case of order please specify one of the options indicated on the below table.

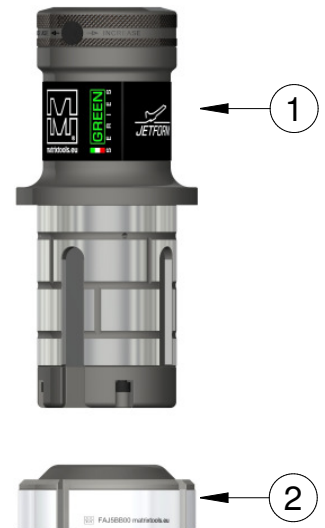

UPPER INSERTS HOLDER			
POS.	DESCRIPTION	CODE	✓
0	Not required	-	<input checked="" type="checkbox"/>
1a	Adjustable round and shaped	FB10BA00	<input type="checkbox"/>
1b	Fixed round and shaped	FAQ9BA00	<input type="checkbox"/>

LOWER INSERTS HOLDER			
POS.	DESCRIPTION	CODE	✓
0	Not required	-	<input checked="" type="checkbox"/>
2	Lower Insert Holder	FB10BB00	<input type="checkbox"/>



Title	M15 00-2.2	Station :	C Thick Turret	Date :	08/01/2013	Telephone :	0039 0445 671015
	Continuous Radius Back Louver	Thickness :	1.80 ÷ 2.50	Rev :	0	Fax :	0039 0445 671035
Code :	FB10237476.844	Forming :	Up	Rev. Date :		E-Mail :	sales@matrixtools.eu

<http://www.matrixtools.eu/catalogues/deformations>

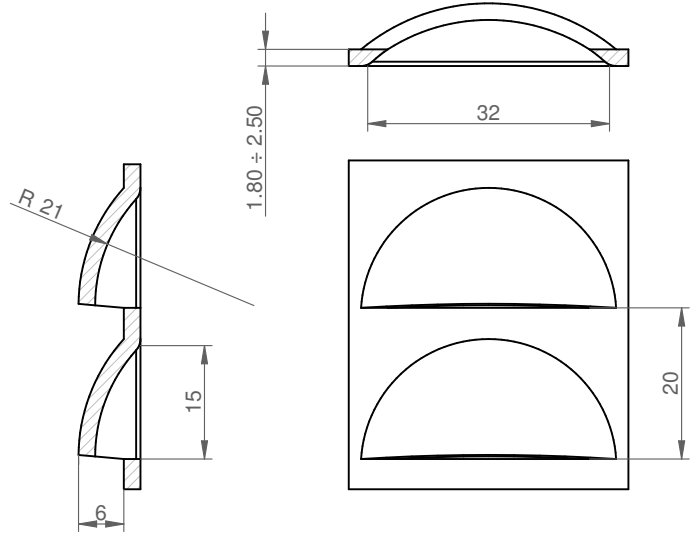
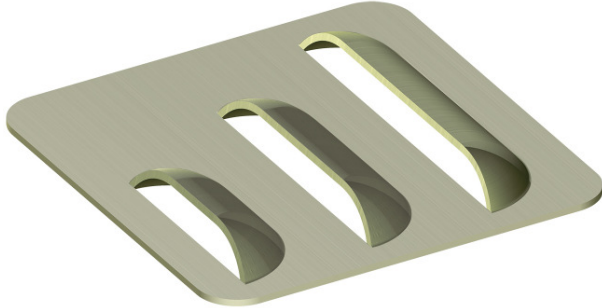

## SET OF INSERTS M15

- To be used on inserts Holder series WHITE and GREEN.
- Multiple close formings might bend the sheet metal.
- Set of inserts composed of all elements showed on the side.

SET OF INSERTS M15			
POS.	DESCRIPTION	CODE	Q.ty
3	Lower Insert	FB10177176	1
4	Spring	A0903326.217	12
5	Upper Shearing insert	FB10CP00	1
6	Stipper	FB10036976	1
7	Upper insert	FB10247276.844	1
8	Screw	A0100100.022	2

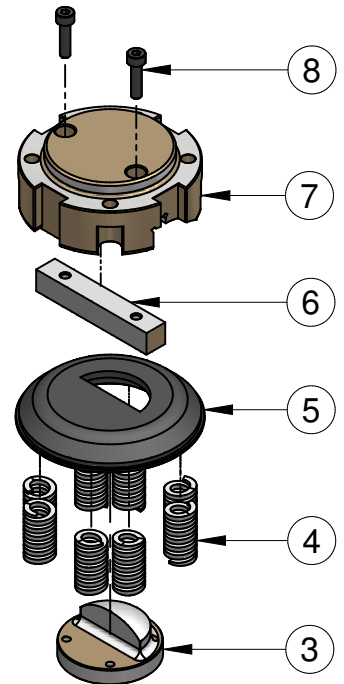

## UPPER INSERTS HOLDER

- Not included on the supply and not included on the price of the set of inserts.
- In case of order please specify one of the options indicated on the below table.

UPPER INSERTS HOLDER			
POS.	DESCRIPTION	CODE	✓
0	Not required	-	<input checked="" type="checkbox"/>
1a	Adjustable round and shaped	FB10BA00	<input type="checkbox"/>
1b	Fixed round and shaped	FAQ9BA00	<input type="checkbox"/>

LOWER INSERTS HOLDER			
POS.	DESCRIPTION	CODE	✓
0	Not required	-	<input checked="" type="checkbox"/>
2	Lower Insert Holder	FB10BB00	<input type="checkbox"/>

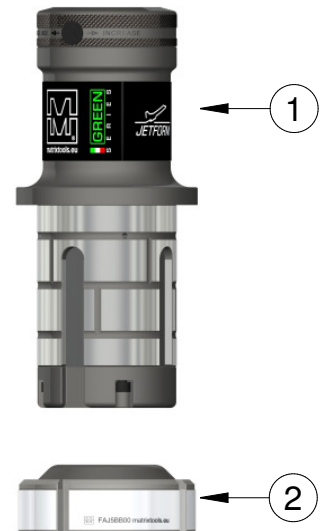



Title M20 04.0-1.2  
Continuous Obround Emboss

Code : FB08237291.979

Station : B Thick Turret

Thickness : 0.80 ÷ 1.60

Forming : Up

Date : 07/01/2013

Rev : 0

Rev. Date :

Telephone : 0039 0445 671015

Fax : 0039 0445 671035

E-Mail : sales@matrixtools.eu

<http://www.matrixtools.eu/catalogues/deformations>

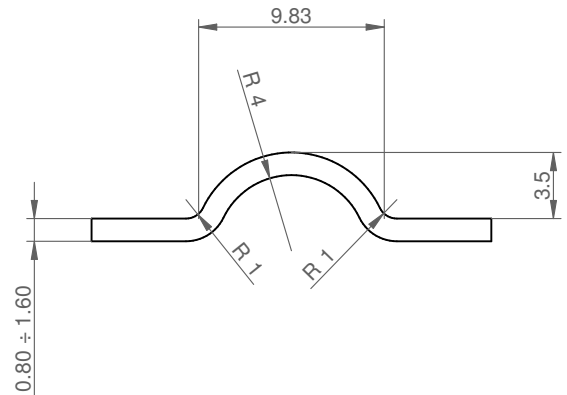
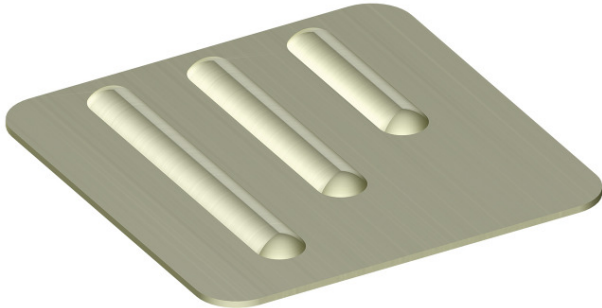

### SET OF INSERTS M20

- To be used on inserts Holder series WHITE and GREEN.
- Multiple close formings might bend the sheet metal.
- Set of inserts composed of all elements showed on the side.

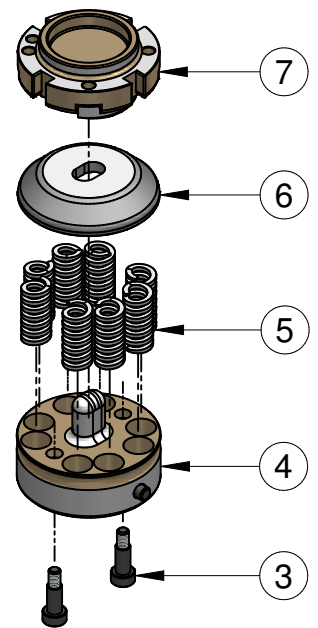

SET OF INSERTS M20			
POS.	DESCRIPTION	CODE	Q.ty
3	Screw	A0116805.019	2
4	Lower Insert	FB08176991	1
5	Spring	A0903326.189	8
6	Stripper	FB08036991	1
7	Upper Insert	FB08247291.979	1

### UPPER INSERTS HOLDER

- Not included on the supply and not included on the price of the set of inserts.
- In case of order please specify one of the options indicated on the below table.



UPPER INSERTS HOLDER			
POS.	DESCRIPTION	CODE	✓
0	Not required	-	✓
1a	Adjustable round and shaped	FB08BA00	
1b	Fixed round and shaped	FB24BA00	



Title	M20 04.0-2.5 Continuous Obround Emboss	Station :	B Thick Turret	Date :	07/01/2013	Telephone :	0039 0445 671015
		Thickness :	2.00 ÷ 3.00	Rev :	0	Fax :	0039 0445 671035
Code :	FB08237291.218	Forming :	Up	Rev. Date :		E-Mail :	sales@matrixtools.eu

<http://www.matrixtools.eu/catalogues/deformations>

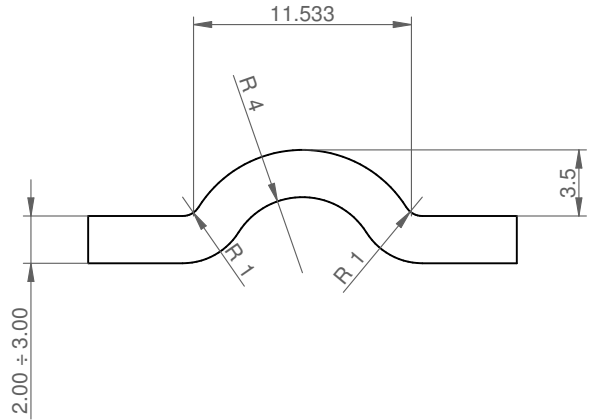

## SET OF INSERTS M20

- To be used on inserts Holder series WHITE and GREEN.
- Multiple close formings might bend the sheet metal.
- Set of inserts composed of all elements showed on the side.

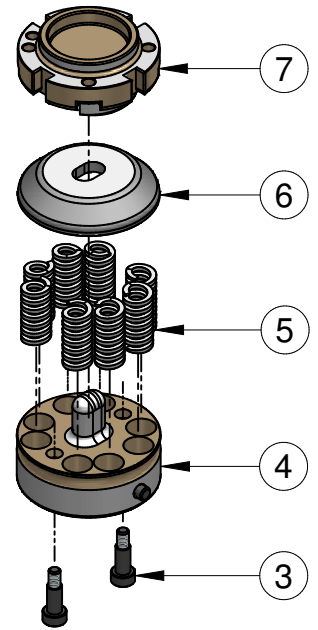

SET OF INSERTS M20			
POS.	DESCRIPTION	CODE	Q.ty
3	Screw	A0116805.019	2
4	Lower Insert	FB08176991	1
5	Spring	A0903326.189	8
6	Stripper	FB08036991	1
7	Upper Insert	FB08247291.218	1

## UPPER INSERTS HOLDER

- Not included on the supply and not included on the price of the set of inserts.
- In case of order please specify one of the options indicated on the below table.



UPPER INSERTS HOLDER			
POS.	DESCRIPTION	CODE	✓
0	Not required	-	✓
1a	Adjustable round and shaped	FB08BA00	
1b	Fixed round and shaped	FB24BA00	











## **MATRIX**

Via Ponte d'Oro, 8 • 36015 • Schio • Vicenza • Italy

T. +39 0445 67.10.15 • F. +39 0445 67.10.35

[www.matrixtools.eu](http://www.matrixtools.eu) • [sales@matrixtools.eu](mailto:sales@matrixtools.eu)